

600 LB. CAST CARBON STEEL FLANGED & BUTTWELD "Y" STRAINERS

MODELS: C8-600 & C7-600

PRESSURE-TEMPERATURE RATINGS	
STEAM:	600 psi @ 838° F
WOG:	1480 psi @ 100° F

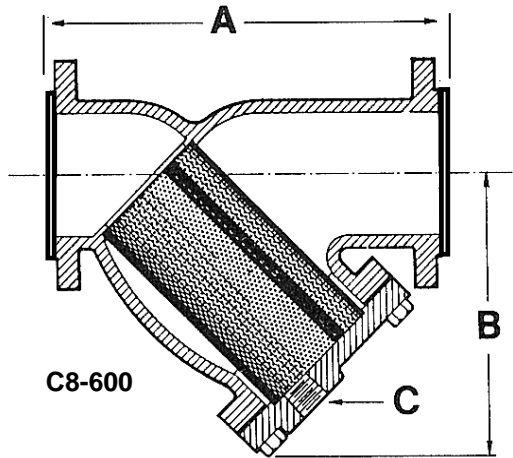

C8-600

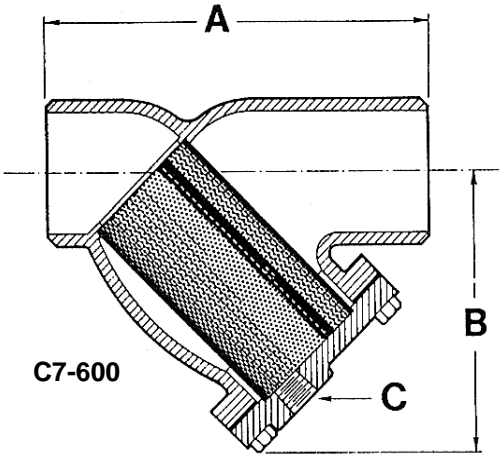

C7-600

DIMENSIONS & WEIGHTS APPROXIMATE
(Apply for certified drawings)

SERVICE RECOMMENDATIONS

These strainers are designed for dependable service under demanding conditions created by high temperatures and pressures. Installation of a strainer before any automatic equipment will ensure trouble free service and avoid costly repairs caused by the existence of foreign matter in pipelines.

FEATURES

All sizes feature a bolted cover machined to receive the screen. The stainless steel spiral wound cover gaskets are designed for high temperature service. Studs are alloy steel. Covers are normally furnished with a blowoff tapping, but without a plug.

Ring Type Joints (RTJ) are available.

SCREENS

Fabrotech supplies sturdy 304 SS screens which are normally furnished in the following perforations:

SERVICE:	1/2" - 4"	5" to 14"
Steam:	.033"	.045"
Liquid :	.062"	1/8"

Other materials, such as Monel, Hastelloy C, & Alloy-20 are available. Other perforation sizes and/or mesh lining is also available.

CONSTRUCTION

Extremely rugged & durable bodies constructed from Carbon Steel (ASTM A216 Gr. WCB). Both models are available in Chrome Moly (ASTM A217 Gr. WC6 & WC9). The standard cover is HRS plate. The bodies of both the C8-600 & C7-600 are designed to meet 600 lb. ANSI specifications. Model C8-600 has RF flanges and model C7-600 ends are machined to match schedule 80 pipe. Other bore schedules are available. All models have machined seats in the body & cover to ensure accurate screen alignment.

SIZE in. mm	1/2" 15	3/4" 20	1" 25	1 1/4" 32	1 1/2" 40	2" 50	2 1/2" 65	3" 80	4" 100	5" 125	6" 150	8" 200	10" 250	12" 300	
A	C8-600	6 5/8	8 5/16	8 5/16	10 1/8	10 1/4	11	12	13 1/2	18	22 1/4	25 5/8	31 3/4	37 3/4	45 1/2
	C7-600	6 5/8	8 5/16	8 5/16	10 1/8	10 1/4	11	12	13 1/2	18	22 1/4	25 5/8	31 3/4	37 3/4	45 1/8
B	C8-600	3 1/2	3 3/4	3 3/4	5 1/2	5 1/2	7	8 1/4	9 1/4	12 1/2	15	20	24	28 1/2	34 1/2
	C7-600	3 1/2	3 3/4	3 3/4	5 1/2	5 1/2	7	8 1/4	9 1/4	12 1/2	15	20	24	28 1/2	34 1/2
C	NPT	3/8	1/2	1/2	1/2	1/2	1	1	1 1/4	1 1/2	2	2	2	2	
WT (lb)	C8-600	6	12 1/4	13	19	27	40	60	78	160	254	364	670	1090	1558
	C7-600	3	9	9	12	13	23	35	47	81	134	200	405	706	880
Clean Cv (gpm)		30	35	40	40	40	70	100	150	250	390	550	900	1500	2200

Also available in sizes 14" thru 24"



Purple Engineering

Australian Distributor:

Phone: +61-1300 62 40 20
 Fax: +61-8-6323 0605
 Email: Sales@Purple-Eng.com.au
 Skype: Purple.Engineering