

600 LB. CAST CARBON STEEL THREADED & SOCKET WELD "Y" STRAINERS

MODELS: C9-600 & C6-600

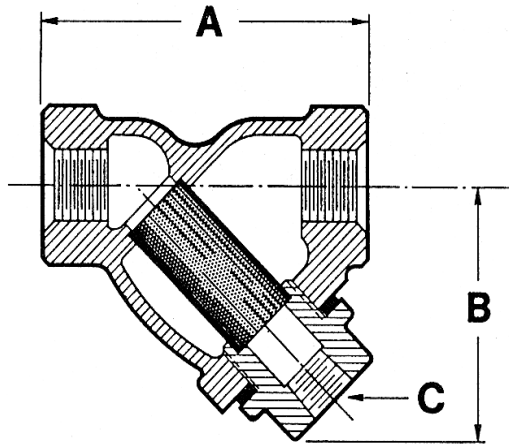

C9-600

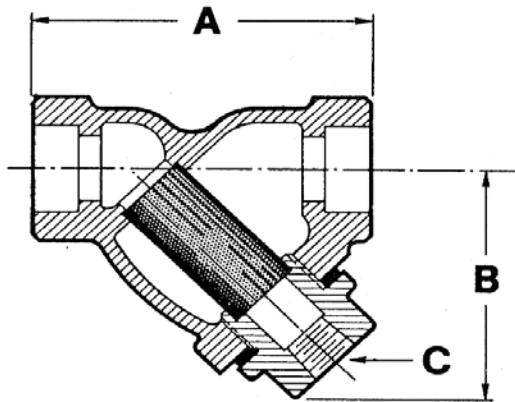

C6-600

DIMENSIONS & WEIGHTS APPROXIMATE
(Apply for certified drawings)

PRESSURE-TEMPERATURE RATINGS	
STEAM:	1010 psi @ 750° F
WOG:	1480 psi @ 100° F

SERVICE RECOMMENDATIONS

Fabrotech models C9-600 and C6-600 are designed for long term use under high pressure and temperature conditions. They will provide excellent protection to mechanical equipment (pumps & valves, etc.) by straining foreign particles from the pipeline. Self cleaning is readily accomplished by opening the plug or valve connected to the blow-off outlet.

FEATURES

The C9-600 & C6-600 contain cast steel straight threaded caps, with an NPT blowoff connection as a standard. Blind caps are available and should be specified when ordering. Fabrotech provides bodies and caps with machined seats which ensure proper screen alignment and reseating.

SCREENS

304 stainless steel screens are normally furnished in the following perforations:

Steam Service: .033"
Liquid Service: .062"

Other materials, such as Monel, Hastelloy-C, & Alloy-20 are available. Other perforation sizes and/or mesh lining is also available. Consult Fabrotech for special applications.

CONSTRUCTION

The body, which is cast from Carbon Steel (ASTM A216, Gr. WCB), is available from stock. Normally furnished with extra heavy bore, but also available to correspond to the inside diameter of standard pipe. The gasket, which is stainless steel spiral wound graphite filled, is limited to 750° F.

INDIVIDUALLY HYDROSTATICALLY TESTED

SIZE in.	1/4"	3/8"	1/2"	3/4"	1"	1 1/4"	1 1/2"	2"
mm	8	10	15	20	25	32	40	50
A	2 15/16	2 15/16	2 15/16	3 11/16	4 9/16	4 15/16	5 9/16	6 15/16
B	2 3/8	2 3/8	2 3/8	2 13/16	3 1/8	4	4 3/4	6
C (NPT)	1/4	1/4	1/4	3/8	3/8	3/4	3/4	1
WT (lb.)	2	2	2	3	5	6.8	9.8	15
Cv (gpm)	9	9	9	18	28	42	60	92



Purple Engineering

Australian Distributor:

Phone: +61-1300 62 40 20
 Fax: +61-8-6323 0605
 Email: Sales@Purple-Eng.com.au
 Skype: Purple.Engineering