

1500 LB. CAST STAINLESS STEEL THREADED & SOCKET WELD "Y" STRAINERS

MODELS: S9-1500 & S6-1500

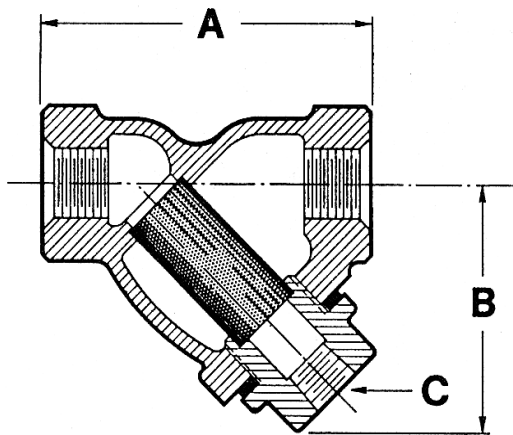

Threaded Cap
(From 1/2" to 1")

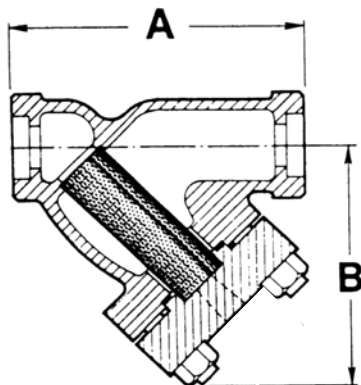

Bolted Cover
(From 1 1/4" to 2")

DIMENSIONS & WEIGHTS APPROXIMATE
(Apply for certified drawings)

SIZE in.	1/2" *	3/4" *	1" *	1 1/4"	1 1/2"	2"
mm	15	20	25	32	40	50
A	3 29/32	4 1/4	5	8 3/8	8 3/8	9 5/16
B	3	3 5/8	4 1/8	7	7	7 3/8
C (NPT)	1/4	3/8	1/2	Blind Cap Std. SW/NPT avail.		
WT (lb.)	2.25	3.75	6.5	22	22	30
Cv (gpm)	9	18	28	42	60	92

* threaded (screwed) cap supplied (sizes 1" and smaller)

PRESSURE-TEMPERATURE RATINGS

STEAM: 1500 psi @ 1125° F

WOG: 3600 psi @ 100° F

SERVICE RECOMMENDATIONS

These strainers are built for long term use under demanding conditions. Because they have been designed to withstand high temperatures and pressures, they are recommended to use for protection to pumps, valves, compressors, etc.

FEATURES

The S9-1500 & S6-1500 have machined seats in the body and cap, which allow for proper screen alignment & seating. Sizes 1/2" through 1" have a screwed cap with a threaded (NPT) connection. Sizes 1 1/4" thru 2" have a bolted cover and are normally furnished blind, a socket weld or NPT blowoff is available & should be specified when ordering.

SCREENS

Fabrotech provides stainless steel screens (grade 304) for all sizes which are normally furnished in the following perforations:

Steam Service: .045"

Liquid Service: .062"

Other body materials, such as Monel, Hastelloy C, and Alloy 20 are available. Other perforation sizes and/or mesh lining are also available. Please consult Fabrotech for options.

CONSTRUCTION

The body, which is cast from Stainless Steel (ASTM A351, Gr. CF8M), is available from stock. Furnished with stainless steel spiral wound gaskets with graphite filler as standard. All sizes contain screens with a minimum capacity of four times the corresponding pipe size. The socket weld bore is in accordance with ANSI B16.11.

INDIVIDUALLY HYDROSTATICALLY TESTED