



Purple Engineering

SIMPLEX BASKET STRAINER ♦ THREADED & FLANGED END

ANSI CLASS 125 ♦ CAST IRON BODY ♦ QUICK-OPEN COVER

MODELS: BS 25-CI

(THREADED)

SIZES: 3/8" ~ 3"

BS 25F-CI

(FLANGED - FLAT FACED)

SIZES: 1" ~ 8"

3/8" - 3" Standard Quick-Open
Cover is Knob Style.

4" - 8" Standard Quick-Open
Cover is Clamp Style.

Designed
for easy maintenance
and large straining
capacities!

4" BS 25F-CI is shown
with standard Quick-Open
Cover & removable leg brackets.

Side Drain is standard
on sizes 4" and up.



FEATURES

- ◇ **VERSATILE - HIGH QUALITY CONSTRUCTION**
THIS BASKET STRAINER IS AVAILABLE WITH EITHER THREADED (BS 25-CI) OR FLAT-FACED FLANGED ENDS (BS 25F-CI). BOTH MODELS HAVE EPOXY-PAINTED CAST IRON BODIES, PLUGGED DRAIN CONNECTIONS, AND SAFETY VENTS IN. A QUICK OPEN COVER COMES STANDARD, BUT A FULL ANSI RATED BOLTED COVER IS ALSO AVAILABLE.
- ◇ **MINIMAL PRESSURE LOSS**
PRESSURE LOSS IS MINIMIZED BY PROVIDING AN OVER-THE-TOP FLOW PATH AND LARGE OPEN AREA RATIO. THE STRAINING CAPACITY IS A MINIMUM OF SIX TIMES THAT OF THE CONNECTING PIPE.
- ◇ **LARGE STRAINING CAPACITY**
WITH ITS LARGE BODY AND SIZEABLE STRAINING ELEMENT, THIS BASKET STRAINER HAS THE ABILITY TO STORE LARGE QUANTITIES OF DEBRIS - THUS MAXIMIZING TIME BETWEEN SERVICING. IT ALSO FEATURES A MACHINED SEAT WITH O-RING THAT ENABLES FINE FILTRATIONS DOWN TO 40 MICRONS.
- ◇ **NUMEROUS STRAINING ELEMENT OPTIONS**
STRAINING ELEMENTS ARE AVAILABLE IN A VARIETY OF PERFORATIONS, MESHES, AND MATERIALS. SPECIAL DESIGNS ARE ALSO AVAILABLE INCLUDING MAGNETIC, WEDGE WIRE, DRILLED PERFORATIONS, AND PLEATED STRAINING ELEMENTS. THE STANDARD MATERIAL FOR STRAINING ELEMENTS IS TYPE 304 STAINLESS STEEL.
- ◇ **SELF-CLEANING OPTION**
UTILIZING A MODIFIED STRAINING ELEMENT, DRAINS CAN BE FITTED WITH A TITAN FCI BALL VALVE TO ALLOW FOR THE AUTOMATIC CLEANING OR FLUSHING OF THE STRAINING ELEMENT WHILE KEEPING THE PIPELINE IN SERVICE.
- ◇ **POTABLE WATER/FDA APPROVED COATINGS AVAILABLE**
IN ADDITION TO ITS LEAD FREE, CAST IRON BODY, TITAN CAN PROVIDE NSF/ANSI AND FDA APPROVED EPOXY COATINGS WHICH MAKE THIS PRODUCT SUITABLE FOR POTABLE WATER AND FOOD CONTACT APPLICATIONS. NUMEROUS OPTIONS ARE AVAILABLE. PLEASE CONTACT US FOR MORE DETAILS.



TECHNICAL

PRESSURE/TEMPERATURE RATING ⁽¹⁾
CAST IRON ASTM A126 GR. B - CLASS 125

BS 25-CI (Threaded) ⁽²⁾
WOG: 200 PSI @ 100 °F
Saturated Steam: Not Recommended
Maximum Liquid: Not Recommended

BS 25F-CI (Flanged) ⁽²⁾
WOG: 200 PSI @ 100 °F
Saturated Steam: Not Recommended
Maximum Liquid: Not Recommended

1. The above listed temperatures are theoretical and may vary during actual operating conditions.
2. Quick-Open (knob-type) cover is not recommended for steam or high temperature. Full ANSI rated bolted cover is also available.

APPLICATIONS

MARKETS: WATER & WASTEWATER, PULP & PAPER, CHEMICAL & PETROCHEMICAL, PETROLEUM, OIL & GAS, TRANSPORTATION, MARINE INDUSTRY, AND FOOD INDUSTRY

GENERAL APPLICATION: SIMPLEX BASKET STRAINERS ARE INSTALLED INTO A PIPELINE SYSTEM TO REMOVE UNWANTED DEBRIS FROM THE PIPELINE FLOW. BASKET STRAINERS ARE COMMONLY USED IN HORIZONTAL PIPELINES WHERE DEBRIS LOADING IS HIGH AND THE COLLECTION OF SOLIDS IS REQUIRED. STRAINING IS ACCOMPLISHED VIA A PERFORATED OR MESH LINED STRAINING ELEMENT, INTERNAL TO THE BASKET STRAINER. IN GENERAL, THE SIZE OF THE PERFORATION OR MESH SHOULD BE SLIGHTLY SMALLER THAN THE SMALLEST DEBRIS PARTICLE TO BE REMOVED. IT IS IMPORTANT TO NOTE THAT THE CORRECT SIZE OF A BASKET STRAINER IS DETERMINED BY ITS JOB FUNCTION, NOT BY THE SIZE OF THE PIPELINE.

The above data represents common market and service applications. No representation or guarantee, expressed or implied, is given due to the numerous variations of concentrations, temperatures and flow conditions that may occur during actual service.



Purple Engineering

Phone: (+61) 1300 62 4020
Email: info@Purple-Eng.com.au
Skype: Purple.Engineering

Providing Equipment for:
Oil & Gas Industry
Pipeline Industry
Marine Industry
Power Generation

www.Strainer.net.au



Phone: (+61) 1300 62 4020
 Email: info@Purple-Eng.com.au
 Skype: Purple.Engineering

Providing Equipment for:
 Oil & Gas Industry
 Pipeline Industry
 Marine Industry
 Power Generation

SIMPLEX BASKET STRAINER

BS 25-CI - (Threaded)

BS 25F-CI - (Flanged - Flat Faced)

Flanged & Threaded Ends • Quick-Open Cover • Cast Iron

**ANSI
 Class 125**

BILL OF MATERIALS ⁽¹⁾

No.	PART	BS 25-CI and BS 25F-CI
1	Body ⁽²⁾	Cast Iron ASTM A126 Gr. B
2	Cover	Knob Cover: Cast Iron ASTM A126 Gr. B Clamp Cover: Carbon Steel A516-70
3	O-Ring / Gasket ⁽³⁾	Buna-N
4	Straining Element ⁽³⁾	Type 304 Stainless Steel
5	Studs	Zinc Plated Alloy Steel
6	Knobs	Zinc Plated Ductile Iron
7	Drain Plugs	Carbon Steel
8	Clamp	Zinc Plated Ductile Iron
9	Bolts	Zinc Plated Alloy Steel A 193-B7
10	Tee Handle	Zinc Plated Carbon Steel

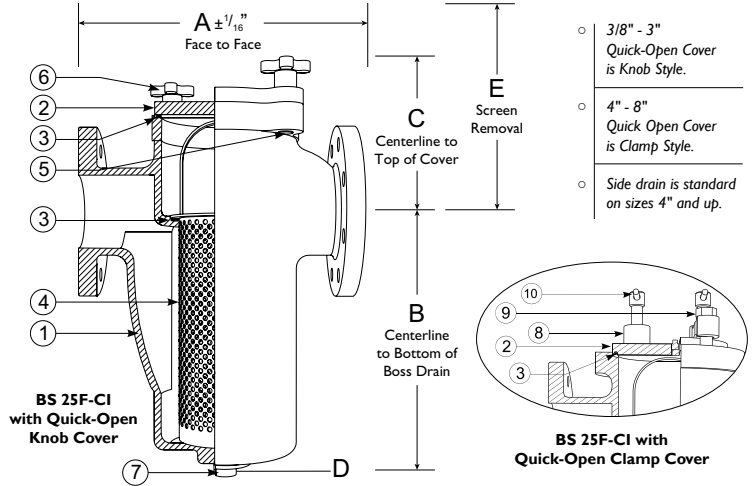

- 3/8" - 3" Quick-Open Cover is Knob Style.
- 4" - 8" Quick Open Cover is Clamp Style.
- Side drain is standard on sizes 4" and up.

1. Equivalent or better materials may be substituted at the manufacturer's discretion.
2. Cast Iron bodies are epoxy painted.
3. Denotes recommended spare parts.

Illustration displays flanged end connections only (BS 25F). Tables to the left and below contain dimensions and material information for both threaded and flanged types. Contact factory for more information on the optional bolted cover. When required, always request certified drawings.

DIMENSIONS AND PERFORMANCE DATA ⁽¹⁾

Size	in	3/8	1/2	3/4	1	1 1/4	1 1/2	2	2 1/2	3	4	6	8
A_T DIMENSION FACE TO FACE (THREADED)	in	4.562	4.562	4.562	5.312	6.312	6.312	8.25	9.625	11.25	n/a	n/a	n/a
	mm	116	116	116	135	161	161	210	245	286	n/a	n/a	n/a
A_F DIMENSION FACE TO FACE (FLANGED)	in	n/a	n/a	n/a	5.687	n/a	7.00	9.00	10.44	11.75	15.00	20.25	27.38
	mm	n/a	n/a	n/a	145	n/a	178	229	267	299	381	515	696
B_T DIMENSION CTR. TO BOSS BOTTOM (THREADED)	in	4.00	4.00	4.00	4.687	6.50	6.50	7.875	8.75	11.375	n/a	n/a	n/a
	mm	102	102	102	120	166	166	201	223	289	n/a	n/a	n/a
B_F DIMENSION CTR. TO BOSS BOTTOM (FLANGED)	in	n/a	n/a	n/a	4.687	n/a	6.50	8.00	8.75	11.50	13.75	20.00	24.24
	mm	n/a	n/a	n/a	120	n/a	166	204	223	293	350	508	616
C_T DIMENSION CTR. LINE TO TOP (THREADED)	in	2.50	2.50	2.50	2.75	3.00	3.00	3.625	4.00	4.50	n/a	n/a	n/a
	mm	64	64	64	70	77	77	93	102	115	n/a	n/a	n/a
C_F DIMENSION CTR. LINE TO TOP (FLANGED)	in	n/a	n/a	n/a	3.00	n/a	3.00	3.75	4.00	4.75	7.00	8.45	12.00
	mm	n/a	n/a	n/a	77	n/a	77	96	102	121	178	215	305
D DIMENSION NPT BLOW-OFF (BOTH)	in	3/8	3/8	3/8	3/8	1/2	1/2	3/4	1	1	2	2	2
	mm	10	10	10	10	15	15	20	25	25	50	50	50
E DIMENSION SCREEN REMOVAL (BOTH)	in	4.812	4.812	4.812	5.875	8.125	8.125	10.125	11.875	14.812	19.875	29.125	29.125
	mm	123	123	123	150	207	207	258	302	377	505	740	943
ASSEMBLED WEIGHT THREADED (APPROXIMATE)	lb	5.5	5.5	5.0	8.0	15.0	14.0	27.0	36.0	55.5	n/a	n/a	n/a
	kg	2.5	2.5	2.3	3.6	6.8	6.4	12.2	16.3	25.2	n/a	n/a	n/a
ASSEMBLED WEIGHT FLANGED (APPROXIMATE)	lb	n/a	n/a	n/a	11.5	n/a	21.0	34.0	48.5	64.0	118.0	266.0	518.0
	kg	n/a	n/a	n/a	5.2	n/a	9.5	15.4	22.0	29.0	53.5	120.7	235.0
Flow Coefficient	C _v	14	14	14	24	43	43	70	90	140	290	780	1600

1. Dimensions, weights, and flow coefficients are provided for reference only. When required, always request certified drawings.

PRESSURE - TEMPERATURE RATINGS ⁽¹⁾

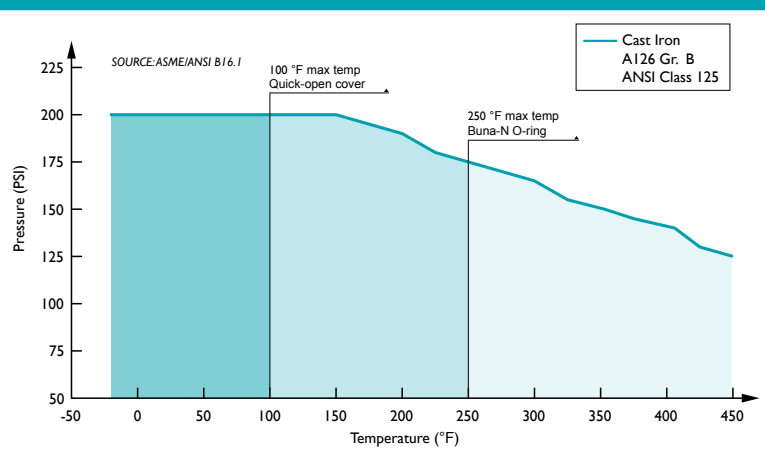

1. This chart displays the pressure-temperature ratings for the strainer's body material per ANSI B16.1. Max temperature limits have been added for Quick-Open cover and Buna-N O-ring.

We make every effort to ensure the information presented on our literature accurately reflects exact product specifications. However, as product changes occur, there may be short-term differences between actual product specifications and the information contained within our literature. We reserve the right to make design and specification changes to improve our products without prior notification. When required, request certified drawings.

REFERENCED STANDARDS & CODES

CODE	DESCRIPTION
ASME/ANSI B16.1	Cast Iron Pipe Flanges and Flanged Fittings
ASME/ANSI B16.4	Cast Iron Threaded Fittings

PRESSURE - TEMPERATURE RATING

ANSI CLASS 125	BS 25-CI	BS 25F-CI
WOG (water, oil, gas)	200 PSI @ 100 °F	200 PSI @ 100 °F
Saturated Steam ⁽¹⁾	Not Recommended	Not Recommended
Max Liquid ⁽¹⁾	Not Recommended	Not Recommended

1. Quick-Open cover is not recommended for steam or high temperatures. Full ANSI rated bolted cover is also available.

STANDARD SCREEN SELECTIONS

Size	Liquid	Open Area	Steam	Open Area
3/8" ~ 2"	1/16 (.0625)	41%	1/32 (.033)	28%
2 1/2" ~ 4"	1/16 (.0625)	41%	3/64 (.045)	36%
5" ~ 8"	1/8 (.125)	40%	3/64 (.045)	36%