



Purple Engineering

"Y" (WYE) STRAINER ❖ ANSI CLASS 250

CAST IRON ❖ THREADED ENDS

MODEL: **YS 12-CI**
(CAST IRON)



3" YS 12-CI

FEATURES

SIZE RANGE : 1/4" ~ 3"

- ❖ **LARGE STRAINING CAPACITY**
WITH ITS LARGE BODY AND SIZABLE STRAINING ELEMENT, THE YS12 PROVIDES EXCELLENT OPEN AREA RATIOS THAT ARE TYPICALLY TWO-AND-A-HALF TIMES LARGER THAN THE CORRESPONDING PIPELINE.
- ❖ **PRECISION MACHINED SEATS**
PRECISION MACHINED SCREEN SEATS IN BOTH THE BODY AND CAP HELP TO ENSURE ACCURATE POSITIONING OF THE SCREEN DURING REASSEMBLY AFTER CLEANING. ALSO, THE MACHINED BODY SEATS ENABLE FINER FILTRATION BY PREVENTING DEBRIS BYPASS.
- ❖ **SELF-CLEANING CAPABILITY**
WITH A TAPPED NPT BLOW-OFF CONNECTION, THIS UNIT CAN BE FITTED WITH A BLOW-DOWN VALVE WHICH FACILITATES CLEANING OF THE STRAINING ELEMENT. PLEASE CONTACT FACTORY FOR MORE INFORMATION.
- ❖ **EPOXY PAINTED**
ALL UNITS ARE EPOXY PAINTED TO HELP RESIST RUST AND CORROSION. TITAN FCI ALSO OFFERS EPOXY COATING AS AN OPTION FOR THE YS12.
- ❖ **POTABLE WATER/FDA APPROVED COATINGS AVAILABLE**

 IN ADDITION TO ITS LEAD FREE, CAST IRON BODY, TITAN CAN PROVIDE NSF/ANSI AND FDA APPROVED EPOXY COATINGS WHICH MAKE THIS PRODUCT SUITABLE FOR POTABLE WATER AND FOOD CONTACT APPLICATIONS. NUMEROUS OPTIONS ARE AVAILABLE. PLEASE CONTACT US FOR MORE DETAILS.
- ❖ **THREADED CAP**
YS12 HAS STRAIGHT THREADS TO PERMIT EASY CAP REMOVAL FOR CLEANING AND PROPER ALIGNMENT WHEN REASSEMBLING STRAINER.
- ❖ **NATURAL GAS AND OTHER SPECIAL APPLICATIONS**
WE HAVE EXTENSIVELY TESTED THE YS12 IN GAS APPLICATIONS AND DETERMINED THAT BUNA-N GASKETS PROVIDE SUPERB SEALING CAPABILITIES FOR THE SERVICE. ALWAYS SPECIFY IF A SPECIAL GASKET OR SCREEN IS REQUIRED FOR A SPECIFIC APPLICATION.

TECHNICAL

PRESSURE/TEMPERATURE RATING
CI-ASTMA126 GR. B - CLASS 250
YS 12-CI (THREADED)

WOG (Non-shock): 400 PSI @ 150 °F
Saturated Steam: 250 PSI @ 406 °F
Maximum Liquid: 250 PSI @ 406 °F

- *The above listed temperatures are theoretical and may vary during actual operating conditions.*

APPLICATIONS

GENERAL APPLICATION: Y-STRAINERS ARE INSTALLED IN A PIPING SYSTEM TO REMOVE UNWANTED DEBRIS FROM THE PIPELINE, PROTECTING EXPENSIVE EQUIPMENT DOWNSTREAM SUCH AS PUMPS, METERS, SPRAY NOZZLES, COMPRESSORS, AND TURBINES. THEY CAN BE PLACED IN A HORIZONTAL OR VERTICAL PIPELINE AS LONG AS THE SCREEN IS IN A DOWNWARD POSITION. STRAINING IS ACCOMPLISHED VIA AN INTERNAL PERFORATED OR MESH LINED STRAINING ELEMENT, THE SIZE OF WHICH SHOULD BE DETERMINED BASED ON THE SIZE OF THE SMALLEST PARTICLE TO BE REMOVED.

SERVICING: THE STRAINING ELEMENT NEEDS REGULAR CLEANING TO PREVENT DEBRIS BUILD UP. IT IS NOT ADVISABLE TO ALLOW THE DIFFERENTIAL PRESSURE TO INCREASE BY 20 PSI. ALTHOUGH CLEANING NORMALLY REQUIRES THE REMOVAL OF THE STRAINING ELEMENT, INSTALLING AND USING A TITAN BLOW-OFF DRAIN VALVE CAN INCREASE THE TIME BETWEEN CLEANINGS.

The above data represents common market and service applications. No representation or guarantee, expressed or implied, is given due to the numerous variations of concentrations, temperatures and flow conditions that may occur during actual service.



Purple Engineering

Phone: (+61) 1300 62 4020
Email: info@Purple-Eng.com.au
Skype: Purple.Engineering

Providing Equipment for:
Oil & Gas Industry
Pipeline Industry
Marine Industry
Power Generation

www.Stainer.net.au



Phone: (+61) 1300 62 4020
 Email: info@Purple-Eng.com.au
 Skype: Purple.Engineering

Providing Equipment for:
 Oil & Gas Industry
 Pipeline Industry
 Marine Industry
 Power Generation

"Y" (WYE) STRAINER
YS 12-CI - (Cast Iron)
 Threaded Ends • Cast Iron • ANSI Class 250

ANSI Class
 250

BILL OF MATERIALS (1)

No.	PART	YS 12-CI
1	Body (2)	Cast Iron A126 Gr. B
2	Cap	Cast Iron A126 Gr. B
3	Straining Element (3)	Stainless Steel (6)
4	Gasket (3) (4)	Grafoil
5	NPT Plug (Blow-off) (5)	Steel

- Bill of Materials represents standard materials. Equivalent or better materials may be substituted at the manufacturer's discretion.
- All units are epoxy painted.
- Denotes recommended spare parts.
- Contact Titan for special gaskets materials, including Buna-N or Viton, for natural gas, hot air, or other applications.
- The YS12 can be furnished with bronze blow-off plug to meet Military Specification WWV-S-2739. Contact factory.
- Stainless Steel Straining Element is available in Type 304 and Type 316 Stainless Steel. A wide range of wire mesh and perforated screens are available. See "Standard Screen Selections" chart below for standard perforations and meshes. Please specify if a non-standard screen is required.

Illustrations are representative of a 2" YS12-CI. Please ask for certified drawings when required.

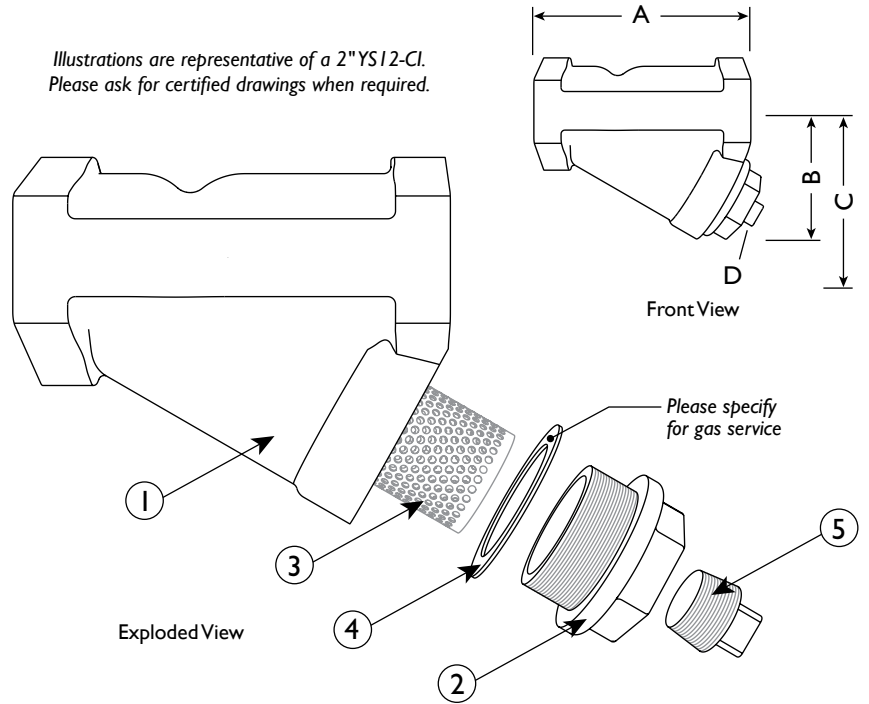

DIMENSIONS AND PERFORMANCE DATA (1)

SIZE	in	1/4	3/8	1/2	3/4	1	1 1/4	1 1/2	2	2 1/2	3
	mm	8	10	15	20	25	32	40	50	65	80
A DIMENSION FACE TO FACE (2)	in	3.188	3.188	3.188	3.75	4.0	5.0	5.75	7.0	9.25	10.0
	mm	81	81	81	95	102	127	146	178	235	254
B DIMENSION CENTER LINE TO BOTTOM	in	2.063	2.063	2.063	2.438	2.625	3.375	3.875	4.75	5.875	6.0
	mm	52	52	52	62	67	86	98	121	149	152
C DIMENSION SCREEN REMOVAL	in	2.375	2.375	2.375	3.0	3.25	4.25	5.0	6.125	7.875	8.0
	mm	60	60	60	76	83	108	127	156	200	203
D NPT Plug BLOW-OFF	in	1/4	1/4	1/4	3/8	3/8	3/4	3/4	1	1 1/2	1 1/2
	mm	8	8	8	10	10	20	20	25	40	40
APPROXIMATE ASSEMBLED WEIGHT	lb	1.5	1.5	1.5	2.5	3.5	6.0	9.0	14.0	25.5	32.0
	kg	0.7	0.7	0.7	1.1	1.6	2.7	4.1	6.3	11.6	14.5
Flow Coefficient	C _v	0.7	2	8	15	22	38	42	70	110	160

- Dimensions and weights are for reference only. When required, request certified drawings.
- Face to face values have a tolerance of ±0.06 in (±2.0 mm).

PRESSURE - TEMPERATURE RATINGS

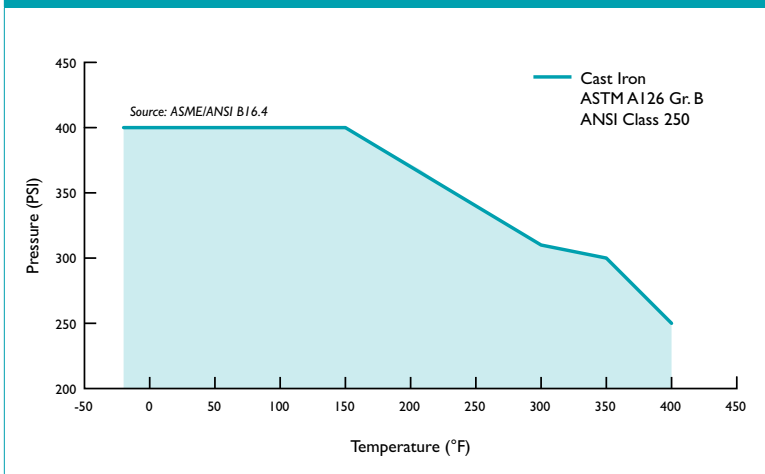

PRESSURE - TEMPERATURE RATING

ANSI Class 250	A126 Gr. B
WOG (Non-shock):	400 PSI @ 150 °F
Saturated Steam:	250 PSI @ 406 °F
Max Liquid:	250 PSI @ 406 °F

STANDARD SCREEN SELECTIONS

Size	Liquid	Open Area	Steam	Open Area
1/4" ~ 2"	20 Mesh	51.8%	30 Mesh	44.8%
2 1/2" ~ 3"	1/16 (.0625)	41%	3/64 (.045)	36%

REFERENCED STANDARDS & CODES

CODE	DESCRIPTION
ASME/ANSI B16.4	Cast Iron Threaded Fittings

We make every effort to ensure the information presented on our literature accurately reflects exact product specifications. However, as product changes occur, there may be short-term differences between actual product specifications and the information contained within our literature. We reserve the right to make design and specification changes to improve our products without prior notification. When required, request certified drawings.