



Purple Engineering

"Y" (WYE) STRAINER ❖ FLANGED ENDS, FLAT FACED ALUMINUM BRONZE ❖ ANSI CLASS 150 ❖ LEAD FREE (1)

Meets LEAD-FREE⁽¹⁾ requirements!

MODELS: **YS 54-AB**
(ALUMINUM BRONZE)

New design includes
gauge taps as standard
on YS54-AB models



FEATURES

SIZE RANGE : 2" ~ 12"

❖ ASTM B148 BODY MATERIAL

ALUMINUM BRONZE IS STRONGER AND LESS LIKELY TO CORRODE THAN OTHER BRONZE ALLOYS, MAKING THEM A PREFERRED CHOICE FOR SEA WATER AND OTHER APPLICATIONS WHERE CORROSION IS A CONCERN. BECAUSE OF ITS COPPER CONTENT, MARINE ORGANISMS CANNOT COLONIZE ON THE MATERIAL. ADDITIONALLY, OUR YS54-AB IS USED FOR POTABLE WATER APPLICATIONS AS IT MEETS LEAD FREE STATUTES REQUIRING THAT THE LEAD CONTENT IN THE WETTED SURFACES IS 0.25% OR LESS AS DETERMINED BY A WEIGHTED AVERAGE.

❖ NEW DESIGN WITH GAUGE TAPS

YS54 HAS CONVENIENT GAUGE TAPS FURNISHED WITH A PLUG ON BOTH THE INLET AND OUTLET SIDES OF SIZES 2" THROUGH 12". THESE TAPS ALLOW FOR EASY INSTALLATION OF PRESSURE GAUGES TO MONITOR DIFFERENTIAL PRESSURE AND DETERMINE WHEN SCREEN CLEANING IS NECESSARY.

❖ LARGE STRAINING CAPACITY

WITH ITS LARGE BODY AND SIZABLE STRAINING ELEMENT, THE YS54 PROVIDES EXCELLENT OPEN AREA RATIOS THAT ARE TYPICALLY TWO-AND-A-HALF TIMES LARGER THAN THE CORRESPONDING PIPELINE, MINIMIZING PRESSURE DROP ACROSS THE VALVE.

❖ PRECISION MACHINED SEATS

PRECISION MACHINED SCREEN SEATS IN BOTH THE BODY AND COVER HELP TO ENSURE ACCURATE POSITIONING OF THE SCREEN DURING REASSEMBLY AFTER CLEANING. ALSO, THE MACHINED BODY SEATS ENABLE FINER FILTRATION BY PREVENTING DEBRIS BYPASS.

❖ SELF-CLEANING CAPABILITY

WITH A TAPPED NPT BLOW-OFF CONNECTION, THIS UNIT CAN BE FITTED WITH A BLOW-DOWN VALVE WHICH FACILITATES CLEANING OF THE STRAINING ELEMENT. PLEASE CONTACT FACTORY FOR MORE INFORMATION.

TECHNICAL

PRESSURE/ TEMPERATURE RATING ⁽²⁾
AB - ASTM B148 GR. 9D - CLASS 150
YS 54-AB (FLANGED)

WOG (Non-shock): 225 PSI @ 150 °F
Saturated Steam: 150 PSI @ 366 °F
Maximum Liquid: 150 PSI @ 406 °F

1. The YS 54-AB meets requirements for lead free use in potable water systems. The lead content in the wetted surfaces is 0.25% or less as determined by a weighted average. For more information on lead free requirements, contact us.
2. The above listed temperatures are theoretical and may vary during actual operating conditions.

APPLICATIONS

GENERAL APPLICATION: Y-STRAINERS ARE INSTALLED IN A PIPING SYSTEM TO REMOVE UNWANTED DEBRIS FROM THE PIPELINE, PROTECTING EXPENSIVE EQUIPMENT DOWNSTREAM SUCH AS PUMPS, METERS, SPRAY NOZZLES, COMPRESSORS, AND TURBINES. THEY CAN BE PLACED IN A HORIZONTAL OR VERTICAL PIPELINE AS LONG AS THE SCREEN IS IN A DOWNWARD POSITION. STRAINING IS ACCOMPLISHED VIA AN INTERNAL PERFORATED OR MESH LINED STRAINING ELEMENT, THE SIZE OF WHICH SHOULD BE DETERMINED BASED ON THE SIZE OF THE SMALLEST PARTICLE TO BE REMOVED.

SERVICING: THE STRAINING ELEMENT NEEDS REGULAR CLEANING TO PREVENT DEBRIS BUILD UP. IT IS NOT ADVISABLE TO ALLOW THE DIFFERENTIAL PRESSURE TO INCREASE BY 20 PSI. ALTHOUGH CLEANING NORMALLY REQUIRES THE REMOVAL OF THE STRAINING ELEMENT, INSTALLING AND USING A BLOW-OFF DRAIN VALVE CAN INCREASE THE TIME BETWEEN CLEANINGS.

The above data represents common market and service applications. No representation or guarantee, expressed or implied, is given due to the numerous variations of concentrations, temperatures and flow conditions that may occur during actual service.



Purple Engineering

Phone: (+61) 1300 62 4020
Email: info@Purple-Eng.com.au
Skype: Purple.Engineering

Providing Equipment for:
Oil & Gas Industry
Pipeline Industry
Marine Industry
Power Generation

www.Strainer.net.au



Phone: (+61) 1300 62 4020
 Email: info@Purple-Eng.com.au
 Skype: Purple.Engineering

Providing Equipment for:
 Oil & Gas Industry
 Pipeline Industry
 Marine Industry
 Power Generation

"Y" (WYE) STRAINER YS 54-AB - (Flanged)

ANSI Class
 150

Flanged (Flat Faced) • ANSI Class 150 • Aluminum Bronze

BILL OF MATERIALS ⁽¹⁾

No.	PART	YS 54-AB
1	Body	Aluminum Bronze ASTM B148 Gr. 9D
2	Cover	Aluminum Bronze ASTM B148 Gr. 9D
3	Straining Element ⁽²⁾	Stainless Steel
4	Gasket ⁽²⁾	Teflon
5	Cap Screw	Stainless Steel or Silicon Bronze
6	NPT Plug (Blow-off)	Aluminum Bronze ASTM B148 Gr. 9D
7	NPT Plug (Gauge Taps)	Aluminum Bronze ASTM B148 Gr. 9D

1. Bill of Materials represents standard materials. Equivalent or better materials may be substituted at the manufacturer's discretion.

2. Denotes recommended spare parts.

Body Material Application Notes:

- Aluminum Bronze (ASTM B148) is a preferred material for lead-free wye strainers, meeting requirements for potable water systems by containing 0.25% lead or less by average weight on all wetted parts.
- Aluminum Bronze is strong and corrosion resistant, meeting the needs of many various applications, such as seawater and marine.

Illustrations are representative of YS 54-AB (Flanged Ends, Flat Faced). Please ask for certified drawings when required.

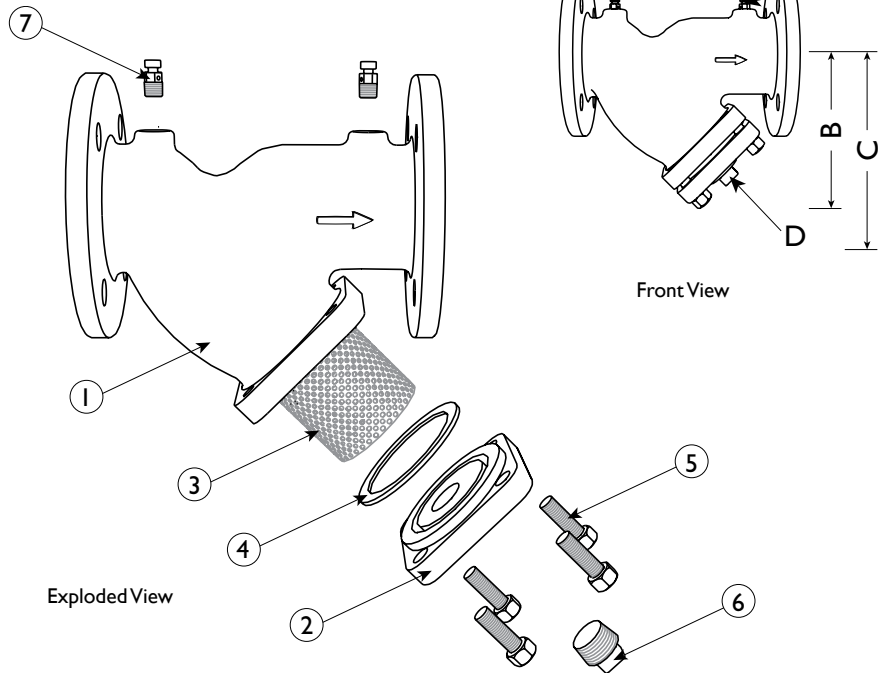

DIMENSIONS AND PERFORMANCE DATA ⁽¹⁾

SIZE	in	2	2 1/2	3	4	5	6	8	10	12
	mm	50	65	80	100	125	150	200	250	300
A DIMENSION FACE TO FACE ⁽²⁾	in	7.75	9.75	10.06	12.12	C/F	18.30	21.37	26.00	C/F
	mm	197	248	256	308	C/F	465	543	660	C/F
B DIMENSION CENTER LINE TO BOTTOM	in	5.25	6.50	7.00	8.25	C/F	13.50	15.50	18.50	C/F
	mm	133	165	178	210	C/F	343	394	470	C/F
C DIMENSION SCREEN REMOVAL	in	7.00	9.75	10.00	12.00	C/F	20.00	22.75	28.00	C/F
	mm	178	248	254	305	C/F	508	578	712	C/F
D NPT Plug BLOW-OFF	in	1/2	1	1	1 1/2	C/F	2	2	2	C/F
	mm	15	25	25	40	C/F	50	50	50	C/F
E NPT Plug GAUGE TAPS	in	1/4	1/4	1/4	1/4	C/F	1/4	1/4	1/4	C/F
	mm	8	8	8	8	C/F	8	8	8	C/F
APPROXIMATE ASSEMBLED WEIGHT	lb	22.0	34.0	38.0	64.0	C/F	132.0	240.0	C/F	C/F
	kg	10.0	15.4	17.2	29.0	C/F	59.9	108.9	C/F	C/F
Flow Coefficient	C _v	70	110	160	260	C/F	570	950	1600	C/F

1. Dimensions and weights are for reference only. When required, request certified drawings.

2. Face to face dimension includes raised face. These values have a tolerance of ±0.06 in (±2.0 mm) for sizes 10" and lower and a tolerance of ±0.12 in (±3.0 mm) for sizes 12" and larger.

PRESSURE - TEMPERATURE RATINGS

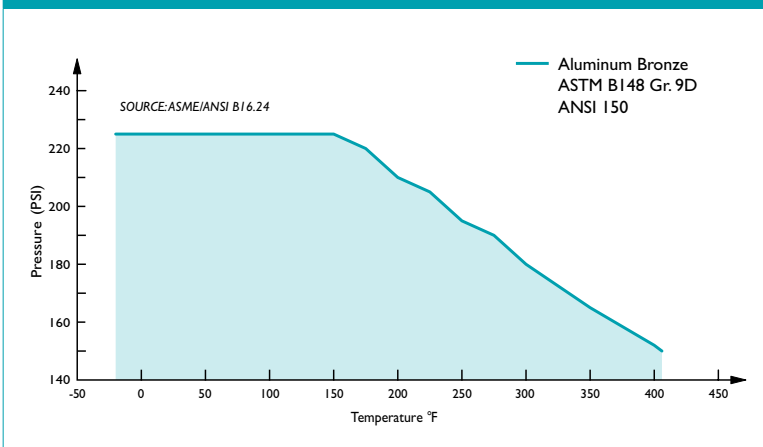

PRESSURE - TEMPERATURE RATING

ANSI Class 150

ASTM B148 Gr. 9D

WOG (Non-shock):

225 PSI @ 150 °F

Saturated Steam:

150 PSI @ 366 °F

Max Liquid:

150 PSI @ 406 °F

STANDARD SCREEN SELECTIONS

Size	Liquid	Open Area	Steam	Open Area
2" ~ 4"	1/16 (.0625)	41%	1/32 (.033)	28%
5" ~ 8"	1/8 (.125)	40%	3/64 (.045)	36%
10" ~ 12"	1/8 (.125)	40%	30 Mesh Lined	44.8%

REFERENCED STANDARDS & CODES

CODE	DESCRIPTION
ASME/ANSI B16.24	Cast Copper Alloy Pipe Flanges and Flanged Fittings

We make every effort to ensure the information presented on our literature accurately reflects exact product specifications. However, as product changes occur, there may be short-term differences between actual product specifications and the information contained within our literature. We reserve the right to make design and specification changes to improve our products without prior notification. When required, request certified drawings.