

# CAST BRONZE THREADED SELF CLEANING "Y" STRAINERS

## MODELS: B9-150 & B9-250

WORKING PRESSURES: NON SHOCK		
STEAM:	B9-150:	150 psi @ 350° F
	B9-250:	300 psi @ 350° F
WOG:	B9-150:	200 psi @ 150° F
	B9-250:	400 psi @ 150° F

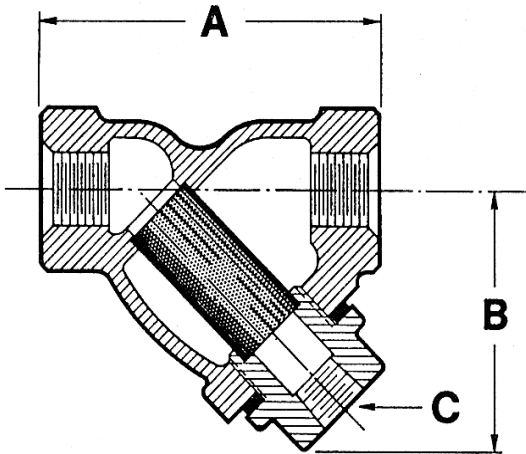

### SERVICE RECOMMENDATIONS

These strainers are used to effectively remove foreign debris from pipelines and protect pumps, meters, valves etc. The use of a strainer is a relatively inexpensive way to protect costly equipment from damage.

### SCREENS

20 mesh 304 stainless steel screens are normally furnished up to and including the 2 inch size. 2 1/2" & 3" are supplied with 1/16" perf.

Other screen materials, such as Monel, Hastelloy-C, & Alloy-20 are available. Other perforation sizes and/or mesh lining are also available.

### CONSTRUCTION

Manufactured from 85-5-5-5 bronze (ASTM B62) because of its superior qualities in high temperature service. The B9-150 and B9-250 are also available for use in military applications. These units, which would be supplied in ASTM B61, conform to BuShip Drawing 80064-810-841499. For military applications, copper gaskets are standard.

### BLOWOFF OUTLETS

Tapped NPT, sizes specified below ("C" dimension). Plugs are not standard, but they can be supplied. Specify at time of order.

### MATERIALS:

**Commercial:** Body & Cap: Bronze ASTM B62 (85-5-5-5)  
Gasket: Non-asbestos

**Military:** Body & Cap: Bronze ASTM B61  
Gasket: Copper

DIMENSIONS & WEIGHTS APPROXIMATE  
(Apply for certified drawings)

### INDIVIDUALLY HYDROSTATICALLY TESTED

SIZE	in.	1/4"	3/8"	1/2"	3/4"	1"	1 1/4"	1 1/2"	2"	2 1/2"	3"
	mm.	8	10	15	20	25	32	40	50	65	80
A	B9-150	3 1/8	3 1/8	3 1/8	3 15/16	4 1/2	5 5/16	6 5/16	7 11/16	9 1/6	10
	B9-250	2 3/4	2 3/4	2 3/4	3	3 3/4	4 7/16	4 15/16	6 1/8	8 1/4	9
B	B9-150	1 15/16	1 15/16	1 15/16	2 5/16	2 7/8	3 1/4	3 3/4	4 3/4	6 1/2	8
	B9-250	2 1/4	2 1/4	2 1/4	2 9/16	2 3/4	3 5/8	3 7/8	5 1/8	6	6 3/4
C	(NPT)	1/4	1/4	1/4	1/4	3/8	3/8	1/2	1/2	1 1/4	1 1/2
WT (lb.)	B9-150	1/2	1/2	1/2	1	1 3/4	2 1/2	4	7	11 1/2	16 1/2
	B9-250	3/4	3/4	3/4	1 1/2	2 1/8	3 1/8	4 1/2	7	12 1/2	18



Purple Engineering

Australian Distributor:

Phone: +61-1300 62 40 20  
 Fax: +61-8-6323 0605  
 Email: info@PRPL.com.au  
 Skype: Purple.Engineering