

250 LB. EXTRA HEAVY CAST IRON FLANGED "Y" STRAINER

MODEL: I8-250

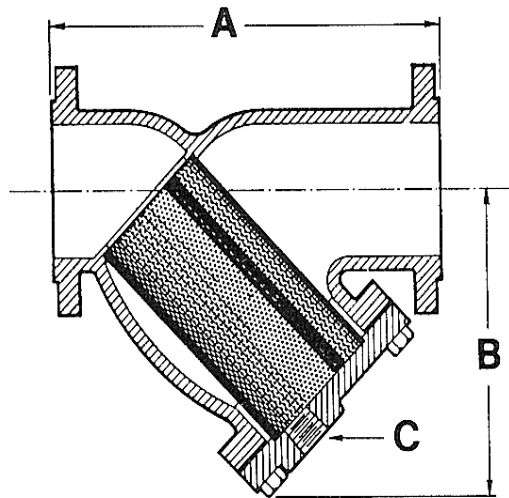

PRESSURE-TEMPERATURE RATINGS	
STEAM: 3/4" to 12"	250 psi @ 450° F
STEAM: 14" to 18"	200 psi @ 400° F
WOG: 3/4" to 12"	500 psi @ 150° F
WOG: 14" to 18"	300 psi @ 150° F

SERVICE RECOMMENDATIONS

The I8-250 is designed to provide economical & dependable protection to mechanical equipment. This unit is engineered for long term use under demanding conditions. Self cleaning is easily accomplished by opening the plug or valve connected to the blowoff outlet (not supplied).

FEATURES

All sizes feature a bolted cover. The cover has a recessed seat which assures correct screen fit. There are bosses located at the

SCREENS

Heavy gauge 304 stainless steel screens are normally furnished in the following perforations:

SERVICE:

Steam:	.045" (1 1/2"-10")	1/16" (12" - 24")
Liquid :	1/16" (1 1/2" - 4")	1/8" (5" - 24")

Other perforation sizes and/or mesh lining is also available.

CONSTRUCTION

The body and cover are constructed from Cast Iron (ASTM A126 B), and the flat gasket is non-asbestos. The blowoff outlets are tapped NPT, and are not normally supplied with plugs.

DIMENSIONS & WEIGHTS APPROXIMATE
(Apply for certified drawings)

INDIVIDUALLY HYDROSTATICALLY TESTED

Size in.	1 1/2"	2"	2 1/2"	3"	4"	5"	6"	8"	10"	12"	14"	16"	18"	20"	24"
mm	40	50	65	80	100	125	150	200	250	300	350	400	450	500	600
A (in.)	8 1/16	9 7/8	11 1/4	12 1/2	14 7/8	17 15/16	20 3/8	24	29 1/2	33 3/4	37 1/4	42 3/8	47 3/4	56	57 1/2
B (in.)	4 3/4	6 3/16	7 5/8	8 1/4	10 1/16	12 1/2	14 5/16	17 3/8	20 7/8	23 9/16	27 1/16	29 1/4	34 3/4	39	45
C (npt)	1/2	1/2	1	1	1 1/4	1 1/4	1 1/2	1 1/2	2	2	2	2	2	2	2
WT (lb)	24	33	49	57	108	157	215	316	525	704	1320	1850	2400	3350	4705



Purple Engineering

Australian Distributor:

Phone: +61-1300 62 40 20
 Fax: +61-8-6323 0605
 Email: info@PRPL.com.au
 Skype: Purple.Engineering