

250 LB. EXTRA HEAVY CAST IRON BODY THREADED "Y" STRAINER

MODEL: I9-250

PRESSURE-TEMPERATURE RATINGS

STEAM:	250 psi @ 400° F
WOG:	400 psi @ 150° F

SERVICE RECOMMENDATIONS

These strainers are built for long term use under moderate pressure and temperature conditions. They protect various types of mechanical equipment such as pumps, valves, meters, compressors, etc. by straining foreign particles from the pipeline. Self cleaning is readily accomplished by opening the plug/valve connected to the blow-off outlet.

FEATURES

The body and cap have machined seats which ensure proper screen alignment and reseating. The cap has a tapped NPT blowoff connection as standard.

SCREENS

20 mesh 304 stainless steel screens are normally furnished in sizes up to and including two (2) inch. 2 1/2" & 3" sizes are furnished with 1/16" perforated 304 stainless steel. Other materials, such as Monel, Hastelloy-C, & Alloy-20 are available. Other perforation sizes and/or mesh lining are also available.

MATERIAL:

The body material is Cast Iron (ASTM A-126, Class B). The standard gasket is non asbestos.

DIMENSIONS & WEIGHTS APPROXIMATE
(APPLY FOR CERTIFIED DRAWINGS)

INDIVIDUALLY HYDROSTATICALLY TESTED

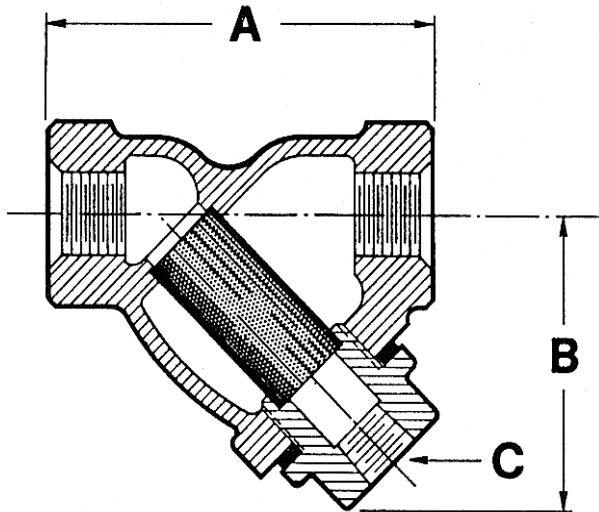

SIZE in.	1/4"	3/8"	1/2"	3/4"	1"	1 1/4"	1 1/2"	2"	2 1/2"	3"
mm	8	10	15	20	25	32	40	50	65	80
A	3 3/16	3 3/16	3 3/16	3 3/4	4	5	5 3/4	7	9 1/4	10
B	2 1/16	2 1/16	2 1/16	2 7/16	2 5/16	3 3/8	3 7/8	4 3/4	5 7/8	6
C (NPT)	1/4	1/4	1/4	3/8	3/8	3/4	3/4	1	1 1/4	1 1/4
WT (lb.)	1 1/2	1 1/2	1 1/2	2 1/2	3	5 1/4	8	12 1/2	22	30



Purple Engineering

Australian Distributor:

Phone: +61-1300 62 40 20
 Fax: +61-8-6323 0605
 Email: info@PRPL.com.au
 Skype: Purple.Engineering