

INSTALLATION, OPERATION, AND MAINTENANCE

PREFACE:

This manual contains information concerning the installation, operation, and maintenance of Simplex Basket Strainers. To ensure efficient and safe operation of Simplex Basket Strainers, the instructions in this manual should be thoroughly read and understood. This manual is general in nature and is not meant to take the place of an on-site, process engineer or pipe fitter. As such, we recommend that only experienced, skilled personnel be allowed to install and maintain Simplex Basket Strainers. Please retain this manual in a location where it is readily available for reference.

GENERAL INFORMATION:

A Basket Strainer is installed into a pipeline system to remove unwanted debris from the pipeline flow. In comparison to WYE Strainers, Basket Strainers are commonly used in pipelines where debris loading is high and the collection of solids is required. Basket Strainers can be installed in a series to provide more effective filtration of unwanted debris. Straining of the pipeline flow is accomplished via a perforated or mesh lined basket, internal to the strainer. In general, the size of the basket perforation should be slightly smaller than the smallest debris particle to be removed. If the basket perforation is undersized, the basket may require excessive cleaning. Consequently, if the basket perforation is oversized, unwanted debris may be permitted to flow through the pipeline, possibly damaging downstream equipment. The correct size of Basket Strainer is determined by its job function, not by the size of the pipeline.

Prior to selection of a Basket Strainer, the following factors must be determined:

- Material construction requirements of the Basket Strainer.
- Design and working pressure/temperature requirements.
- Operating conditions (throttling, pressure drop, condensation, flow reversal, operation frequency, etc.).
- Service media type (liquid, gas, abrasive, corrosive, dirty, etc.).
- Pipeline Media Flow-rate and Viscosity.
- Debris Size to be removed and debris loading of the pipeline.
- Ability to interrupt flow for servicing and cleaning
- Clean Start-up Pressure of the Pipeline.
- Space availability for installation.

Please contact our Design Engineer to assist in the determination of these requirements prior to selection and purchase.

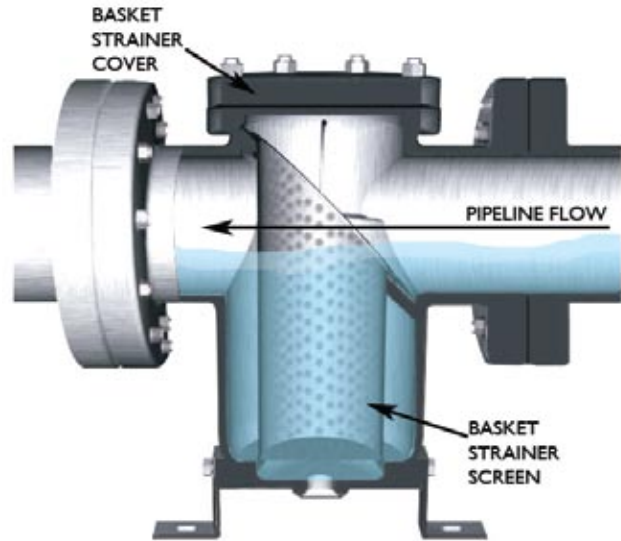

Figure 1: Simplified Illustration of Installed Basket Strainer with Bolted Cover

SIMPLEX BASKET STRAINER

1

BSIOM0709

UNPACKING AND INSPECTION:

Upon receipt of product, it is important to follow these unpacking and inspection procedures.

All of our Basket Strainers are shipped in specialized shipping containers designed to prevent damage during transportation. If external damage to the shipping container is evident upon receipt of product, please request that a representative of the shipping carrier be present before unpacking the product.

- Carefully open the shipping container, following any instructions that may be marked on the container. Remove all packing material surrounding the Basket Strainer and carefully lift it from the container. It is recommended to keep the shipping container and all packing material for reuse in storage or reshipment.

CAUTION:

For large or heavy Basket Strainers, the appropriate material handling equipment must be used to prevent injury and possible damage to the Basket Strainer.

INSTALLATION, OPERATION, AND MAINTENANCE

UNPACKING AND INSPECTION: Continued...

- Visually inspect the Basket Strainer for any signs of damage including scratches, loose parts, broken parts or any other physical damage that may have occurred during shipment. If damage is observed, immediately file a claim with the shipping carrier. Basket Strainers that are damaged during transportation are the responsibility of the customer. For information regarding our warranty policy, please refer to the last page of this document.
- Before installation, the Basket Strainer's cover should be removed and inspected internally for any loose or foreign materials that may have become trapped in the screen during transportation. After inspection, ensure sealing surfaces are clean and replace the gasket and cover. Make sure the gasket is seated correctly before tightening the cover bolts.
- If the Basket Strainer is not required to be installed immediately, it should be stored indoors in a clean, dry, consistent temperature environment. It is also recommended to utilize the original shipping container and packing materials to properly store the Basket Strainer. If long term storage is required, a desiccant may be necessary. This would be based upon the local, environmental storage conditions. Please consult our Design Engineer to assist in this determination.
- When ready to install, remove any preservatives with solvent dampened cloths. Remove any loose material and protective packing material.

INSTALLATION:

Pre-Installation Checklist

- Ensure Working conditions (pressure and temperature) are within the specified capacity of the product being installed. Please refer to the certified Engineering drawings to assist in determining these values.
- Make sure that the construction material of the Strainer is chemically compatible with the media flowing in the pipeline.

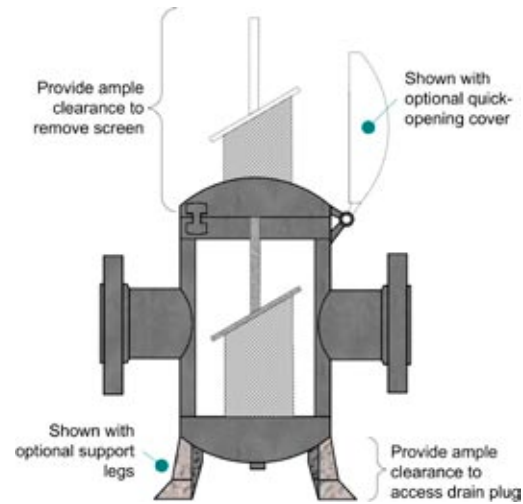

Figure 2: Basket Strainer (Fabricated Design)

Pre-Installation Checklist continued...

- Inspect the Basket Strainer's flange ends and the pipeline's mating flanges to ensure gasket surfaces are free of defects. The pipeline should also be checked for proper alignment. our Basket Strainers should never be utilized to realign an existing piping system.
- Ensure that the pipeline's mating flanges are the same type as the Basket Strainer being installed. Raised face flange ends cannot be mated to flat face flange ends.
- Ensure that the pipeline set-up allows a horizontal installation of the Basket Strainer; Simplex Basket Strainers can only be installed in horizontal pipelines.
- If pipeline strain is a concern when installing larger Basket Strainers (6" and above), a concrete or steel pad should be used to provide additional support. Larger Basket Strainers can also be fitted with legs to assist in reducing strain on the pipeline.
- If the Basket Strainer is to be located on the discharge side of a pump, then a safety release valve must be installed between the Basket Strainer and the pump.

INSTALLATION, OPERATION, AND MAINTENANCE

INSTALLATION: Continued...

Installation Procedure

Step 1:

Our Basket Strainers must be positioned in the pipeline ahead of the equipment requiring protection. If the equipment requiring protection is a pump, the Basket Strainer must be placed on the suction side of the pump.

Step 2:

To provide for easier maintenance, the Basket Strainer should be located where the drain plug can be removed and where there is ample space above the Basket Strainer for screen removal. Refer to the certified engineering drawing to determine the screen clearance requirements.

Step 3:

Before placing the Basket Strainer into place, support the existing pipeline with pipe supports near the inlet and outlet connections of the Basket Strainer.

Step 4:

Place the Basket Strainer into the pipeline, ensuring that the flow arrow on the body of the Basket Strainer is pointing in the direction of the pipeline flow. For large or heavy Basket Strainers, lift the Basket Strainer into place using slings positioned underneath the inlet and outlet connections.

Step 5:

Install a standard, ANSI (1/8" thick) flange gasket between the Basket Strainer and pipeline flanges, on both sides. Install lubricated flange bolts and hand tighten. Flange bolts should then be tightened, using a star or crisscross pattern to evenly load the bolts, in accordance with established piping standards. This is illustrated in Figure 3.

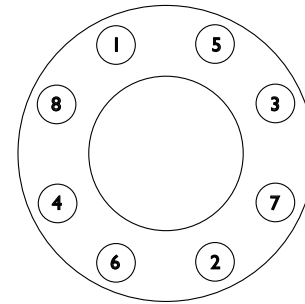

Figure 3: Bolting Sequence Pattern

OPERATION:

Once proper installation has been successfully completed, start the system gradually, at start up as well as after shut down. This eliminates sudden shock to the strainer and other equipment in the line.

Start-up Procedure:

Step 1:

Remove air from the pipeline by opening the blow-down valve or other vent near the Basket Strainer.

CAUTION:

With piping systems that contain fluids other than water or when the working temperature is above 120° F, fluid must be drained to safe area, away from the operator. Operators should always be fitted with appropriate protective equipment when venting is performed.

Step 2:

Start the piping system by opening the outlet valve nearest the Basket Strainer's outlet first. Then gradually open the inlet valve nearest the Basket Strainer's inlet, approximately 25% of normal operational flow. It is important to start the system gradually to avoid displacing or damaging the Basket Strainer.

Step 3:

Continue to open the inlet valve until the desired service flow has been reached.

Step 4:

Close blow-down valve or other pipeline vent.

CAUTION:

Excessive bolt torque may damage flanges. Please refer to established flange bolt torques for guidelines.

INSTALLATION, OPERATION, AND MAINTENANCE

MAINTENANCE:

Our Simplex Basket Strainers require little monitoring once they are properly installed. The pressure differential across the basket should be checked periodically to determine if the basket needs to be cleaned or replaced. If the pressure differential goes unchecked and the screen becomes completely clogged, the screen will break and require replacing.

CAUTION:

Basket Strainer screens are not designed to withstand the same pressure ratings as the housings. If the basket becomes completely clogged, it will be exposed to the same pressure as the housing. In most cases, this will cause the basket to fail and potentially damage downstream equipment.

Our Basket Strainers are designed to require very little maintenance. Regular maintenance involves:

- Periodically checking for leaks.
- Timely cleaning or replacement of screen.

During normal use, the basket will become clogged with foreign matter, causing the differential pressure to increase. Once the differential pressure has increased to an unacceptable value, typically by 5 psi to 10 psi, it is time to clean or replace the basket. It is not advisable to let the differential pressure increase by 20 psi. This may cause the screen to fail and possibly damage downstream equipment.

A convenient and safe way to determine when the basket needs to be replaced is to install pressure gauges on the inlet and outlet sides of the Basket Strainer. The maximum acceptable pressure drop across the Basket Strainer will indicate when the screen needs to be replaced. Basket size and construction determine the maximum pressure drop a Basket Strainer screen can withstand. Please consult factory for exact pressure ratings.

Strainer Element Cleaning

CAUTION:

Before removing the cover of the Basket Strainer, the pressure inside the vessel must be reduced to atmospheric via suction or venting. Failure to do so may result in serious bodily injury.

Strainer Element Cleaning: continued...

CAUTION:

Before removing the Basket Strainer's cover, ensure that the media that is flowing in the pipeline is known and any special handling precautions are understood. Please review the Material Safety Data Sheet (MSDS) for that specific fluid.

Step 1:

Isolate the Basket Strainer by closing the inlet and outlet valve connections on either side of the Basket Strainer.

Step 2:

Open vent or drain plug to relieve pressure inside the Basket Strainer. Drain fluid up to screen seat level.

Step 3:

Once pressure is relieved, remove the cover.

Step 4:

Remove basket and clean. Avoid banging or hitting the screen to remove stubborn debris. It is recommended to use a high pressure water or air stream to clean screen.

Step 5:

Inspect basket and cover gasket for damage. If either is damaged, replace. Always ensure there is a spare gasket and basket on hand prior to maintenance.

Step 6:

Remove any debris or sludge from within the Basket Strainer.

Step 7:

Replace clean basket into its original position, ensuring it is squarely positioned on the screen seat.

Step 8:

Replace cover gasket and replace and tighten cover.

Follow the Start-up procedure outlined within the OPERATION section of this manual.



INSTALLATION, OPERATION, AND MAINTENANCE

SPARE PARTS LIST:

For the bill of materials and spare parts listing of each Basket Strainer model, please refer to the corresponding Engineering Specification Sheet. For special or fabricated units, please refer to the certified engineering drawing for that unit.

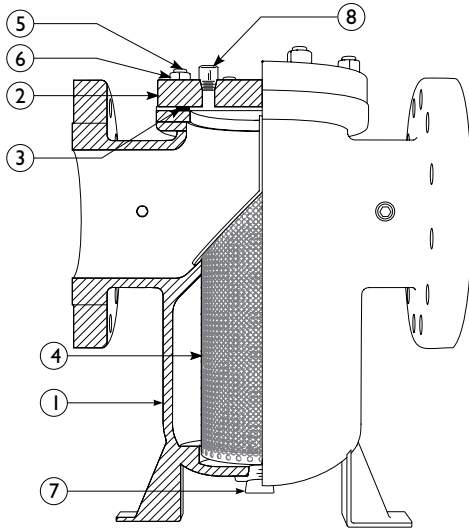

Figure 4: CAD Illustration

SAMPLE PARTS LIST	
No.	Simplex Basket Strainer
1	BODY
2	COVER
3*	COVER GASKET
4*	BASKET
5*	STUD
6	NUT
7	NPT PLUG
8	NPT PLUG

* Denotes recommended spare parts

WARRANTY:

Seller warrants each of the products and parts sold hereunder, under normal use of service, and subject to user's compliance with any operating instructions and other directions given by seller, to be free from defects in materials or workmanship for a period of one year from date of shipment from seller's plant. Seller's liability, under this warranty, shall be limited to, at the seller's option, to repairing or replacing any such defective product FOB seller's plant in Lumberton, NC, and reimbursing purchaser for shipping costs, subject to the following: (1) Timely receipt of purchaser's written notice that such products are defective. (2) Seller's written authorization to purchaser for the return of such products, (3) the return of such products to seller with shipping charges prepaid and (4) seller's inspection of and confirmation that such products are defective in materials or workmanship. If seller's inspection shows that the products returned are defective due to dirt, rust or any foreign material not attributable to seller: improper usage, over tightening on threads, abuse or incorrect assembly in the field, or other cause not due to seller's improper manufacture, seller will, subject to purchaser's written authorization, repair or replace such products at cost. Seller's factory inspection and testing reports will be made available to purchaser upon request.

THIS WARRANTY IS IN LIEU OF ANY OTHER WARRANTIES, EXPRESS OR IMPLIED, INCLUDING ANY IMPLIED WARRANTY OF FITNESS OR MERCHANTABILITY. SELLER SHALL NOT BE LIABLE FOR ANY SPECIAL, INCIDENTAL OR CONSEQUENTIAL DAMAGES. NO REPRESENTATIVE OR SELLER HAS AUTHORITY TO MAKE ANY REPRESENTATIONS OR WARRANTIES, EXCEPT AS STATED HEREIN.

