

NO.	PART NAME	MATERIAL
1	BODY	CAST IRON ASTM A 126 GR. B
2	SCREEN	S.S. 304
	PERF. DIA.	1/16" in Sizes 1" to 4", 1/8" in size 5" to 8"
	MESH	
3	COVER	DUCTILE IRON (SG IRON)
4	YOKE	DUCTILE IRON (SG IRON)
5	YOKE SCREW	S.S. 304
6	O-RING	VITON
7	STUD	S.S. 304
8	DRAIN PLUG	S.S. 304
9	BODY PLUG	S.S. 304
10	COVER CLAMP	DUCTILE IRON (SG IRON)

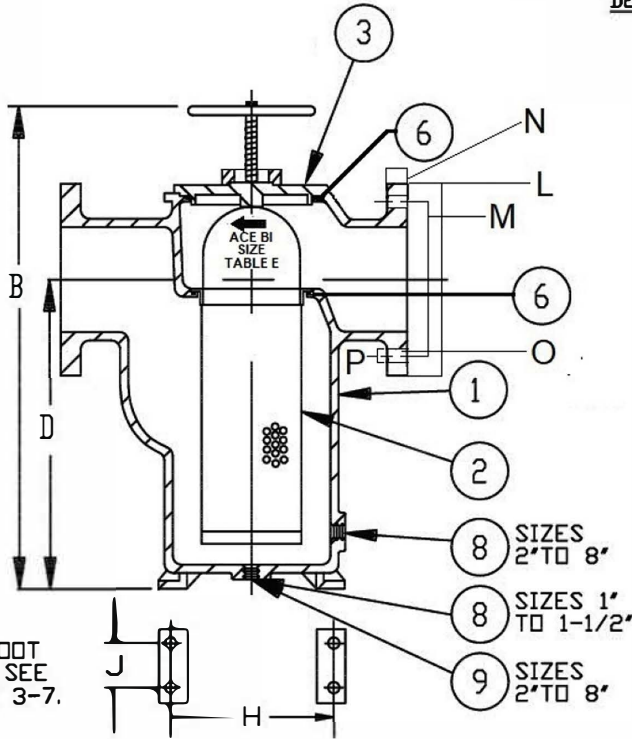

NOTES :

01. Flanged Connections as per BS 10 Table E – Flat Face.
02. Cover Clamp (Item 10) for 100 mm, 125 mm and 150 mm Size
03. No Foot Pad for Size 25 mm
04. 7/16"Ø Slotted Foot Pads For Size 50 mm
05. 1/2" Ø Slotted Foot Pads for Size 65 mm and 80 mm
06. 9/16" Ø Holed Foot Pads for Size 100 mm, 125 mm and 150 mm
07. 5/8" Ø Slotted Foot Pads for Size 200 mm
08. Dimensions 'B' and 'D' are from Bottom of Strainer
09. Dimension 'G' (NPT) (Item No 8) is measured as Outside Diameter of Threaded Part of Drain Plug
10. Item 9, Body Plug is not to be used as Drain.
11. 'B' and 'D' in 25 mm Size will be measured with Drain Plug Installed
12. Item No 3 has Viton O Ring Groove Fitted in Cover to achieve tight sealing.
13. Max Working Pressure : 200 PSI (14 Kg/cm²) at 100°F (38°C)
14. Viton Rubber Seal will be provided between Body and Filter Screen Contact Area.
15. 200 mm (8") Size Cover & Yoke will be as per above shown drawing.

FOR FOOT PADS, SEE NOTES 3-7.

Size	Valve Dimension								Flange Dimensions					
	A	B	C	D	G	H	J	K	L	M	N	O	P	
25	194	280	102	143	21	---	---	109	115	83	8	4	14	
50	268	372	172	197	21	140	64	146	150	114	12	4	18	
65	295	417	202	227	16.5	165	73	168	165	127	12	4	18	
80	334	476	203	270	16.5	178	80	185	185	146	13	4	18	
100	425	500	272	273	21	254	99	238	215	178	14	8	18	
125	460	650	272	392	21	254	118	257	255	210	15	8	18	
150	499	735	272	465	21	254	127	275	280	235	18	8	22	
200	686	950	----	693	48	400	219	394	335	292	19	8	22	
TOTAL														

L = Flange OD, M = PCD, N = Thickness, O = No. of Holes, P = Hole Diameter
 All Dimensions are in mm
 (Dimensions Tolerance : ± 3 mm)

	SIGN	DATE
DRN.	SKP	04-04-19
CHD.	KMP	04-04-19
APPD.		
SCALE	N.T.S.	

POT STRAINER (Cast Basket Strainer)

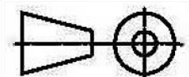

SHEET NO.

MATERIAL:-	AS SHOWN	QTY:-
DRG. NO.	ACE-BI-451-2018	REVISION



Phone: (+61) 1300 62 4020
 Email: info@PRPL.com.au
 Skype: Purple.Engineering

Providing Equipment for:
 Oil & Gas Industry
 Pipeline Industry
 Marine Industry
 Power Generation