



Purple Engineering

Phone: (+61) 1300 62 4020
Email: info@PRPL.com.au
Skype: Purple.Engineering

Providing Equipment for:
Oil & Gas Industry
Pipeline Industry
Marine Industry
Power Generation

ASTM CLASS 800 FORGED STEEL Y-STRAINER

Model : ACE-YF-800

Feature

- SS-304 Perforated Screen + Mesh #40 lining (400 Micron)
- Y Type Structure
- Connection: Threaded End, Socket End
- Thread Type: NPT, BSPT, DIN
- Working Temperature: -15 c ~ 440 c OR 5.4~822.6 °F (A105)
-25 c ~ 524 c OR -14.4~957.6 °F (S.S.)
- Material: A105, F304, F316, F11, F22, F304L, F316L
- 3.1 Certification



Standard

- Manufacture and Design API 602. API 6D. API
- Inspection and Test 594 API 598

Parts and Material

NO.	Part Name	Material		
1	BODY	A105	F304	F316
2	SCREEN	STAINLESS STEEL		
3	GASKET	GRAPHITE+304	GRAPHITE+316	
4	CAP	A105	F304	F316
5	BLOW OFF PLUG	Optional - Untapped		
6	CAP BOLT	A193 B7	A193 B8	

* Special alloys are available upon request

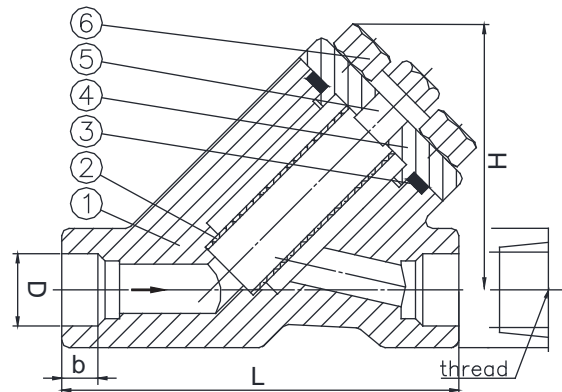

Dimensions (mm):

INCH	DN Stock	D Thread	D Socket	b	L	H	Weight KG
1/2"	15	15	21.8	9.6	98	84	2.7
3/4"	20	20	27.1	12.7	98	84	2.5
1"	25	25	33.8	12.7	120	102	6.3
1-1/4"	32	32	42.6	12.7	140	114	9.2
1-1/2"	40	40	48.7	12.7	140	114	9.2
2"	50	50	61.1	15.9	170	145	10.3

* We reserve the rights of any alternative dimension without any notice.

Please reconfirm exact dimensions at the time of order.

** Stock strainers to be machines by end user to Threaded or Socket weld or other connection types.



Purple Engineering

Australian Distributor

Phone: 1300 62 40 20
Fax: +61-8-6323 0605
Email: info@PRPL.com.au
Skype: Purple.Engineering