



290 Corporate Dr  
www.titanfci.com  
Phone: 910.735.0000

Lumberton, NC 28358  
titan@titanfci.com  
Fax: 910.738.3848

**2" - 24" FDO 20 & FDO 30 Series Duplex Strainer**

ASME Class 150, 300

**BILL OF MATERIALS<sup>(1)</sup>**  
**FDO 20 & FDO 30 Series**

Part	FDO 20 & FDO 30 Carbon Steel	FDO 20 & FDO 30 Stainless Steel
1 Body	Carbon Steel A106 Gr.B	Stainless Steel SA312 Type 316
2 Tee	Carbon Steel A234	Stainless Steel SA403 Type 316
3 Nozzle	Carbon Steel A106 Gr.B	Stainless Steel SA312 Type 316
4 Cover	<b>Bolted:</b> Carbon Steel A105 <b>Quick-Open:</b> Carbon Steel A516 Gr. 70	<b>Bolted:</b> Stainless Steel SA182 Type 316 <b>Quick-Open:</b> Stainless Steel Type 316
5 Body Flange	Carbon Steel A105	Stainless Steel SA182 Type 316
6 Inlet/Outlet Flange	Carbon Steel A105	Stainless Steel SA182 Type 316
7 Pipe Cap	Carbon Steel A234 Gr.WPB	Stainless Steel SA403 Type 316
8 Straining Element <sup>(2)</sup>	T304 SS	T304 SS
9 Gasket/O-Ring <sup>(2)</sup>	<b>Bolted Cover:</b> Spiral Wound Stainless Steel <b>Quick-Open:</b> Buna-N <sup>(3)</sup>	
10 Lifting Lug	Carbon Steel	Stainless Steel
11 Butterfly Valve	Butterfly Valve: BF 76 Ductile Iron Body, Ductile Iron Nickel Coated Disc <sup>(4)</sup> , Buna/EPDM Seat with Gear Operator	
12 Drain	Carbon Steel A105	Stainless Steel SA182 Type 316
13 Vent with Plug <sup>(4)</sup>	Carbon Steel A105	Stainless Steel SA182 Type 316
14 Studs	Carbon Steel A193 B7	Stainless Steel A193 B8 M
15 Nuts	Carbon Steel A194 2H	Stainless Steel A194 Gr.8
16 T-Bolt	Carbon Steel S A325	Stainless Steel
17 T-Bolt Closure	Carbon Steel	Stainless Steel Type 316
18 Support Legs <sup>(5)</sup>	Carbon Steel	Stainless Steel

1. Bill of Materials represents standard materials. Equivalent or better materials may be substituted at the manufacturer's discretion.  
2. Titan recommends keeping spare parts on hand.  
3. Buna-N is standard for applications below 250° F. Viton is standard for applications 250° F and above.  
4. 1/2" NPT is standard.  
5. Stainless Steel discs are used for applications requiring all stainless parts.  
6. Support legs are optional. Call factory.

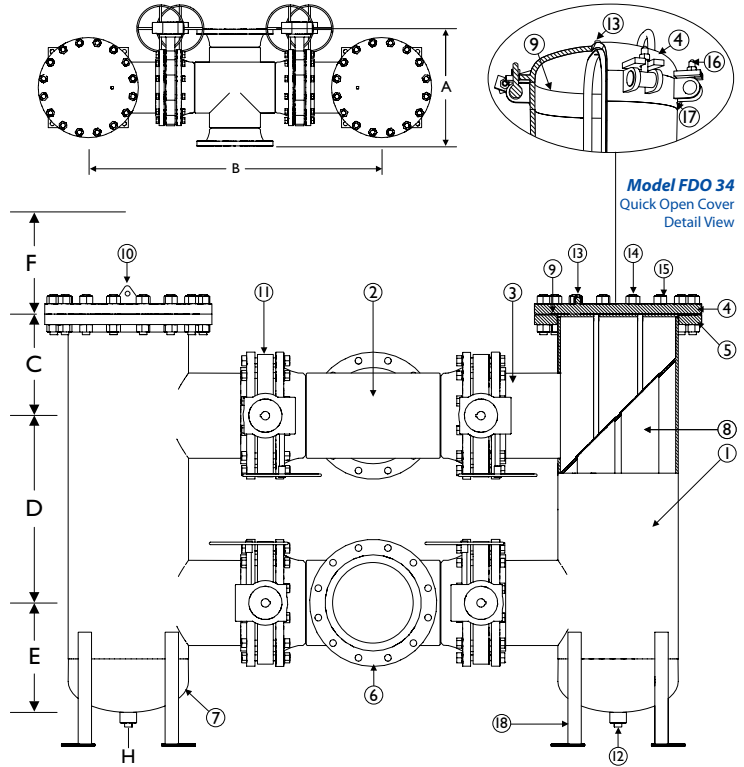

Model FDO 31

Model FDO 34 Quick Open Cover Detail View

Illustrations are representative of Titan FCI fabricated duplex strainers; however, as with all fabricated designs, actual products may vary. Illustration is representative of multi-basket style (sizes 12" and up). 2" - 10" are single basket style.

**Certified drawings are required for all Titan fabrications. Support legs are optional, contact factory for details.**

**FDO 20 & FDO 30 Series Offset Duplex Strainer Dimensions: 2" - 24" | ASME CLASS 150, 300**

**DIMENSIONS AND WEIGHTS<sup>(1)</sup>**

	in	2	3	4	6	8	10	12	14	16	18	20	24
<b>A - Face to Face<sup>(2)</sup></b> FDO 21, FDO 24, FDO 31, FDO 34	mm	50	80	100	125	150	200	250	350	400	450	500	600
	in	10.25	12.50	14.50	18.50	22.25	25.25	29.25	32.25	34.25	38.25	41.63	46.25
	mm	260	318	368	470	565	641	743	819	870	972	1057	1175
<b>B - Center Column to Center Column</b>	in	32.18	34.63	43.25	49.63	55.75	62.44	73.25	78.25	85.00	90.50	101.88	114.13
	mm	817	880	1099	1261	1416	1586	1861	1988	2159	2299	2588	2899
<b>C - Center of Top Valve to top<sup>(3)</sup></b>	in	6.63	7.25	8.75	10.00	11.25	13.25	15.19	15.75	18.19	18.19	23.13	27.06
	mm	168	184	222	254	286	337	386	400	462	462	588	687
<b>D - Valve to Valve</b>	in	13.00	13.00	17.00	17.00	21.00	25.00	28.00	30.00	34.00	36.00	40.00	48.00
	mm	330	330	432	432	533	635	711	762	864	914	1016	1219
<b>E - Center of Bottom Valve to Bottom<sup>(4)</sup></b>	in	6.69	6.63	8.25	10.31	12.31	14.38	16.38	18.00	20.50	21.50	22.50	24.50
	mm	170	168	210	262	313	365	416	457	521	546	572	622
<b>F - Screen Removal</b>	in	24.00	25.00	32.00	34.00	40.00	47.00	53.00	56.00	64.00	67.00	77.00	91.00
	mm	610	635	813	864	1016	1194	1346	1422	1626	1702	1956	2311
<b>H - NPT</b>	in	.75	.75	1.00	1.00	1.50	1.50	1.50	2.00	2.00	2.00	2.00	2.00
	mm	19	19	25	25	38	38	38	51	51	51	51	51
<b>Approximate Weight</b>	lb	370.00	450.00	690.00	1100.00	1750.00	2550.00	4100.00	4300.00	6100.00	6500.00	9950.00	15250.00
	kg	168.00	204.00	313.00	499.00	794.00	1157.00	1860.00	1951.00	2767.00	2948.00	4513.00	6917.00

1. Dimensions and weights of FDO 21, FDO 24, FDO 31, & FDO 34 are provided for reference only. Certified drawings are required for all Titan fabrications.  
2. Face to face values have a tolerance of ±0.06 in (±2.0 mm) for sizes 10" and lower and a tolerance of ±0.12 in (±3.0 mm) for sizes 12" and larger.  
3. Centerline dimension is from the top of body housing. Does not include cover. Quick open cover dimension is to the top of body housing.  
4. Center of Bottom Valve to Bottom dimension is to bottom of body housing and does not include the NPT plug.

†Titan FCI's fabricated products are made to each customer's unique specifications. Dimensions, materials, and all other product details referenced in this literature are general in nature. Some options may not be available in all sizes and/or models. †Titan FCI reserves the right to make design and specification changes to improve the products without prior notification. **For exact product specifications, please consult the Titan FCI factory and request certified engineering drawings.**