

## Engineering Specification

Job Name \_\_\_\_\_

Contractor \_\_\_\_\_

Job Location \_\_\_\_\_

Approval \_\_\_\_\_

Engineer \_\_\_\_\_

Contractor's P.O. No. \_\_\_\_\_

Approval \_\_\_\_\_

Representative \_\_\_\_\_

# Cast Aluminum Bronze Flanged End Y Strainers

Models: 851M, Class 150

852, Class 300

Sizes: ½" – 12" (15 – 300mm)

### Typical Service

- Used extensively to strain foreign matter from pipe lines and provide economical protection for costly pumps, meters, valves, and other similar mechanical equipment

### Features

- Sizes through 4" feature tapered, self-aligning seats.
- Larger sizes feature a machined seat for the screen, eliminating particle bypass.

### Construction

- Flanged cover, flat faced and drilled.

### Self-Cleaning

- Self-cleaning is accomplished by opening the plug or valve connected to the blowoff outlet.

### Blowoff Outlets

- Outlets are NPT tapped, at location C.
- Sizes of tapping specified on next page.
- Not normally furnished with plug. Plug available, specify with order.
- Please specify if strainer is to be mounted vertically. If so, the cover will be rotated to position the blowoff at the lowest point.

### Capacity

- Generously proportioned bodies
- Open Area Ratio much greater than pipe size, ensuring low pressure drop

### Screens

MODEL	SIZES	STANDARD (WATER)		STEAM RECOMMENDATION	
		MATERIAL	OPENING	MATERIAL	OPENING
851M, 852	½" – 4"	304SS	.062 perf	304SS	0.033 perf
	5" – 8"	304SS	.062 perf	304SS	.045 perf
	10" and Up	304SS	.125 perf	304SS	.062 perf

Mueller Steam Specialty product specifications in U.S. customary units and metric are approximate and are provided for reference only. For precise measurements, please contact Mueller Steam Specialty Technical Service. Mueller Steam Specialty reserves the right to change or modify product design, construction, specifications, or materials without prior notice and without incurring any obligation to make such changes and modifications on Mueller Steam Specialty products previously or subsequently sold.

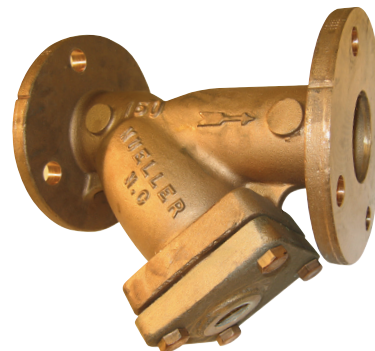

Model 851M

Pressure/Temperature–Non-Shock		
Model	Material	Rating
851M	Al-Brz	225 psi @ -20° to 150°F 15.5 bar @ 29°C to 66°C 150 psi @ 400°F 11.9 bar @ 200°C
852	Al-Brz	500 psi @ -20° to 100°F 34.5 bar @ -29°C to 66°C 375 psi @ 400°F 26.1 bar @ 200°C

\* 851M supersedes model 851.

### NOTICE

The information contained herein is not intended to replace the full product installation and safety information available or the experience of a trained product installer. You are required to thoroughly read all installation instructions and product safety information before beginning the installation of this product.



A WATTS Brand

## Material

	851M	852
Body	Aluminum Bronze ASTM B148	Aluminum Bronze ASTM B148
Cover	Aluminum Bronze ASTM B148	Aluminum Bronze ASTM B148
Gasket	Metal Filled Graphite	Metal Filled Graphite

## Dimensions and Weights

SIZE		DIMENSIONS				WEIGHT			
		A		B		C (NPT)			
in.	mm	in.	mm	in.	mm	in.	mm	lbs.	kgs.
<b>851M</b>									
1/2	15	5 7/8	149	3 1/4	83	3/8	10	7	3.1
3/4	20	7 3/8	187	3 3/4	95	1/2	15	13	5.9
1	25	7 3/8	187	3 3/4	95	1/2	15	13	5.9
1 1/4	30	6 5/8	168	4 5/16	125	1/2	15	17	7.7
1 1/2	40	6 11/16	170	4 5/16	110	1/2	15	17	7.7
2	50	7 7/8	200	5 1/4	133	1/2	15	28	12
2 1/2	65	9 3/4	248	6 1/2	165	1	20	38	17
3	80	10	254	7	178	1 1/4	32	64	29
3 1/2	90	CF	CF	CF	CF	CF	CF	CF	CF
4	100	12 1/8	308	8 1/4	210	1 1/2	40	84	38
5	125	15 1/2	394	11 1/4	286	2	50	140	63
6	150	18 7/16	468	13 1/2	343	2	50	160	72
8	200	24	610	16 1/2	413	2	50	296	134
10	250	27 5/8	702	19 3/8	492	2	50	408	185
12	300	32 1/2	826	22 5/8	575	2	50	798	362
<b>852</b>									
1/2	15	6	152	3 1/4	83	3/8	10	12	50.4
3/4	20	7 13/16	198	3 3/4	95	1/2	15	18	8.1
1	25	7 13/16	198	3 5/8	92	1/2	15	18	8.1
1 1/4	32	8	203	4 1/2	114	1/2	15	26	11
1 1/2	40	8 7/8	206	4 3/4	121	1/2	15	26	11
2	50	9	229	6	152	1/2	15	28	12.7
2 1/2	65	10 5/8	270	7 3/8	187	1	20	48	21
3	80	12 1/2	318	9 1/16	230	1 1/4	32	75	34
3 1/2	90	14 1/8	359	9 1/16	230	1 1/4	32	88	40
4	100	15 1/8	384	10 7/8	276	1 1/2	40	110	50
5	125	18 5/8	479	13 9/16	344	2	50	164	74
6	150	19 1/8	486	15 7/8	403	2	50	212	96
8	200	25 3/16	640	16 1/2	413	2	50	359	163
10	250	29 1/8	740	19 3/8	492	2	50	493	224
12	300	34	864	22 5/8	575	2	50	938	425

\*CF = Consult Factory

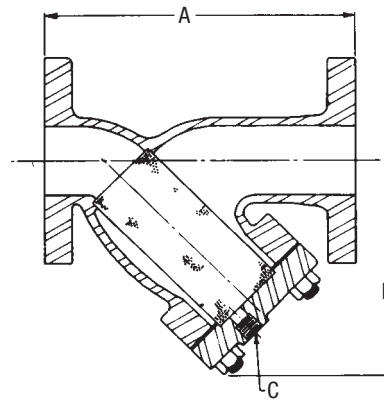

Model 851M, 852

## Pressure Drop

- See Pressure Drop Charts found on the Mueller Steam Specialty web site.

**Limited Warranty:** Mueller Steam Specialty warrants each product to be free from defects in material and workmanship under normal usage for a period of one year from the date of original shipment. In the event of such defects within the warranty period, the Company will, at its option, replace or recondition the product without charge. This shall constitute the sole and exclusive remedy for breach of warranty, and the Company shall not be responsible for any incidental, special or consequential damages, including without limitation, lost profits or the cost of repairing or replacing other property which is damaged if this product does not work properly, other costs resulting from labor charges, delays, vandalism, negligence, fouling caused by foreign material, damage from adverse water conditions, chemical, or any other circumstances over which the Company has no control. This warranty shall be invalidated by any abuse, misuse, misapplication or improper installation of the product. **THIS WARRANTY IS IN LIEU OF ALL OTHER WARRANTIES, EXPRESS OR IMPLIED, INCLUDING ANY IMPLIED WARRANTIES OF MERCHANTABILITY OR FITNESS FOR A PARTICULAR PURPOSE.** Any implied warranties that are imposed by law are limited in duration to one year.

Some States do not allow limitations on how long an implied warranty lasts, and some States do not allow the exclusion or limitation of incidental or consequential damages. Therefore the above limitations may not apply to you. This Limited Warranty gives you specific legal rights, and you may have other rights that vary from State to State. You should consult applicable state laws to determine your rights.



A WATTS Brand