

Models: 41T, 42T, 44T, 46T

Job Name _____

Contractor _____

Job Location _____

Approval _____

Engineer _____

Contractor's P.O. No. _____

Approval _____

Representative _____

Fabricated Tee Strainers

Models: 41T, 42T, 44T, 46T**Size: 2" - 24"**

PRESSURE/TEMPERATURE–NON-SHOCK	
MODEL	RATING
41T	285psi @ 100°F
	150psi @ 565°F
42T	740psi @ 100°F
	300psi @ 838°F
44T	1480psi @ 100°F
	600psi @ 838°F
46T	2220psi @ 100°F
	900psi @ 838°F

Quick opening cover only available for Class 150

41T	Class	150
42T	Class	300
44T	Class	600
46T	Class	900

Typical Service

- Mueller Steam Specialty fabricated strainers are designed to remove foreign particles from pipelines.
- These strainers provide effective and economical protection of pumps, valves, and similar more costly equipment.

Construction

- Standard Class 150, 300, 600 and 900 units available
- Butt-weld or Slip-on Flange connections
- Butt-weld, Weld-neck flange, Ring Joint connections available
- ASME code stamp strainers available

Screens

- Standard material is 304SS.
- Specify other alloy material as required.
- Specify perforation and mesh size for proper particle retention.
- Consider maximum allowable pressure drop when specifying.

**Models 41T, 42T, 44T, 46T**

General

- See Screen and Basket Options in the mueller Steam Specialty Engineering binder for a partial listing of available options and specification guidelines. "B" signifies a bolted cover; "Q" signifies a quick opening cover.
- Consult factory for specific application information.
- See Specifying Fabricated Strainers page in the Mueller Steam Specialty Engineering binder for guidelines.

NOTICE

The information contained herein is not intended to replace the full product installation and safety information available or the experience of a trained product installer. You are required to thoroughly read all installation instructions and product safety information before beginning the installation of this product.

Mueller Steam Specialty product specifications in U.S. customary units and metric are approximate and are provided for reference only. For precise measurements, please contact Mueller Steam Specialty Technical Service. Mueller Steam Specialty reserves the right to change or modify product design, construction, specifications, or materials without prior notice and without incurring any obligation to make such changes and modifications on Mueller Steam Specialty products previously or subsequently sold.

STRAINER
Purple Engineering

Mueller Steam Specialty™

A WATTS Brand

Dimensions and Weights

SIZE		DIMENSIONS						WEIGHT					
		A _F Flanged End		A _W Weld End		C		E Screen Removal		Hinge Cover		Total	
in.	mm	in.	mm	in.	mm	in.	mm	in.	mm	lbs.	kgs.	lbs.	kgs.
QUICK OPENING COVER 41T													
6	150	18¼	464	11¼	286	9⅞	219	19	486	7	3.1	108	49
8	200	22	559	14	356	10⅞	292	23⅞	606	10	4.5	156	70
10	250	25	635	17	432	13⅞	356	29⅞	752	15	6.8	231	105
12	300	29	737	20	508	15⅞	406	34⅞	866	20	9	342	155
14	350	32	813	22	559	17⅞	445	37⅞	943	26	11	435	197
16	400	34	864	24	610	18⅞	483	40⅞	1032	30	13	540	245
18	450	38	965	27	686	21⅞	546	46⅞	1178	42	19	660	300
20	500	41⅞	1051	30	762	23⅞	610	51⅞	1035	54	24	806	366
24	600	46	1168	34	864	27⅞	699	58⅞	1483	68	30	1085	493

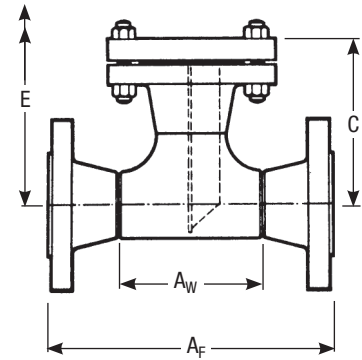

Models 41T, 42T, 44T, 46T

SIZE		DIMENSIONS						WEIGHT					
		A _F Flanged End		A _W Weld End		C		E Screen Removal		Flanged End		Weld End	
in.	mm	in.	mm	in.	mm	in.	mm	in.	mm	lbs.	kgs.	lbs.	kgs.
BOLTED COVER 41T													
2	50	10	254	—	—	5¼	146	11¼	286	30	10	18	8
2½	65	11½	292	—	—	6⅝	168	12⅞	329	—	—	—	—
3	80	12¼	311	—	—	7⅞	179	14	356	50	23	30	14
4	100	14¼	362	—	—	8⅞	205	16½	419	84	38	54	24
5	125	16¾	425	—	—	9⅞	237	19½	495	—	—	—	—
6	150	18¼	464	—	—	10⅞	257	21½	546	146	66	96	44
8	200	22	559	—	—	12⅞	308	26¼	667	230	104	152	69
10	250	25	635	—	—	13⅞	348	30¼	768	352	160	247	112
12	300	29	737	—	—	15¼	400	35⅞	894	526	239	366	166
14	350	32	813	—	—	17⅞	441	38⅞	987	220	100	522	237
16	400	34	864	—	—	18⅞	468	41⅞	1063	904	410	624	283
18	450	38	965	—	—	20⅞	522	45⅞	1165	1078	489	778	353
20	500	41⅞	1051	—	—	22⅞	568	51¼	1302	1426	647	1066	484
24	600	46	1168	—	—	24⅞	631	57⅞	1470	2098	952	1578	716
BOLTED COVER 42T													
2	50	10½	268	5	127	6⅞	156	11¼	298	41	19	23	10
2½	65	12	305	6	152	7	178	13⅞	341	—	—	—	—
3	80	13	330	6¾	171	7⅞	194	14⅞	373	82	37	52	24
4	100	15	381	8¼	209	8¾	222	17¼	438	125	57	75	34
5	125	17½	445	9¼	248	10⅞	257	20⅞	511	—	—	—	—
6	150	19	483	11¼	286	10⅞	262	22¼	565	231	105	147	67
8	200	22¾	578	14	356	13	330	26⅞	684	355	161	241	109
10	250	26¼	667	17	432	15	381	31½	800	543	246	361	164
12	300	30¼	768	20	508	17⅞	435	36½	927	825	374	545	247
14	350	33¼	845	22	559	18¾	476	40⅞	1019	1102	500	742	337
16	400	35½	902	24	610	20	508	43⅞	1102	1398	634	898	407
18	450	39½	1003	27	686	22⅞	562	48⅞	1229	1818	825	1178	534
20	500	42¾	1085	30	762	23⅞	606	52⅞	1329	2342	1062	1542	699
24	600	47¼	1200	34	864	26⅞	670	59⅞	1502	3502	1589	2342	1062

* Consult factory for dimensions and weights for Class 600, 900, 1500 and 2500 units.

Limited Warranty: Mueller Steam Specialty warrants each product to be free from defects in material and workmanship under normal usage for a period of one year from the date of original shipment. In the event of such defects within the warranty period, the Company will, at its option, replace or recondition the product without charge. This shall constitute the sole and exclusive remedy for breach of warranty, and the Company shall not be responsible for any incidental, special or consequential damages, including without limitation, lost profits or the cost of repairing or replacing other property which is damaged if this product does not work properly, other costs resulting from labor charges, delays, vandalism, negligence, fouling caused by foreign material, damage from adverse water conditions, chemical, or any other circumstances over which the Company has no control. This warranty shall be invalidated by any abuse, misuse, misapplication or improper installation of the product. **THIS WARRANTY IS IN LIEU OF ALL OTHER WARRANTIES, EXPRESS OR IMPLIED, INCLUDING ANY IMPLIED WARRANTIES OF MERCHANTABILITY OR FITNESS FOR A PARTICULAR PURPOSE.** Any implied warranties that are imposed by law are limited in duration to one year.

Some States do not allow limitations on how long an implied warranty lasts, and some States do not allow the exclusion or limitation of incidental or consequential damages. Therefore the above limitations may not apply to you. This Limited Warranty gives you specific legal rights, and you may have other rights that vary from State to State. You should consult applicable state laws to determine your rights.



A WATTS Brand

